

HVAC Project of offices on Tashkenti str.

Table of contents	
Explanational note	2
Heat loss calculations	3-7
Heat gane calculations	8
Drawings of Heating and Cooling project	8-19
Drawings of Ventilation project	20-28
Isometric drawings of Ventilation systems	29-34

Explanational Note

The following design is for the central Heating, Ventilation and Air conditioning systems for commercial premises (offices and studios), located on Tashkenti Street, Tbilisi, Georgia (land reg: 06/040).

Design is based upon HVAC, climatology and architectural-technology legal norms of Georgia, and per the requirements of the client.

The climate needs methodology based upon:

Winter: $T(ex)=-8\text{ C}$

Summer: $T(ex)=+36\text{ C}$

Need: $T(in)=+22 - +25\text{ C}$

The cooling supply source are two chillers (each CC 257kwh), with hydronic kit. (+0,00)

The heating supply source are stationary gas condensing boilers, working in cascade, 290 kwh each. (+0,00)

The HVAC system is mixed, including 2-pipe and 4-pipe distributors.

For fresh air preparation, the heat pump/chiller with CC 185 kwh, HC 200kwh is considered.

For the critical winter period, to compensate for the heat pump capacity loss, additional Hot Water Accumulation Tank with 50 kwh of electrical heater (5x10 kwh) is considered.

For the air supply and exhaust, are considered 5 Air Handling units, located on the rood.

Air refresh rate, per the client's needs, is calculated:

- *Office floors 100 persons each tenant floor, with air capacity of 35 m³/h per tenant.*
- *-7,0 – 50 m³/h per tenant*
- *-3,5 – 50 m³/h per tenant*

For the Kitchen exhaust, there is considered independent system (roof)

For the Toilets exhaust, there is considered independent system (rood)

Расчет теплопотерь здания

№ помещения	Наименование помещения	В помещении 2 и более наружные стены	Температура помещения tв, °С	Характеристика ограждений					Сопротивление теплопередаче ограждения R, м²·°С/Вт	Расчетная разность температуры (tв - tн), °С	Добавочные теплопотери β			Кoeffициент (1+Σβ)	Теплопотери, Вт		
				Наименование	Ориентация	Длина	Высота	Площадь			На ориентацию по сторонам горизонта	На проемы в стенах	При 2-х и более наружных стенах		Через ограждения	На нагрев инфильтрующегося воздуха	Помещения в целом
1	2	3	4	5	6	7	8	9	11	12	13	14	15	16	17	18	19
Этаж на отм. -10.000																	
1001	sawyobi		16	ПлII	Нет	6.8	3.0	20.3	4.3	26	0	0	0	1	122		370
				ПлIII	Нет	7.5	3.0	22.5	8.6	26	0	0	0	1	68		
				ПлIV	Нет	6.8	7.5	51.0	14.2	26	0	0	0	1	93		
															284	85	
1002	sawyobi		16	ПлI	Нет	4.0	3.0	12.0	2.1	26	0	0	0	1	149		280
				ПлIII	Нет	4.0	5.0	20.0	8.6	26	0	0	0	1	60		
															209	63	
1003	sawyobi		16	ПлI	Нет	6.8	3.0	20.4	2.1	26	0	0	0	1	253		430
				ПлIII	Нет	6.8	3.8	25.8	8.6	26	0	0	0	1	78		
															331	99	
1004	avtofarexi		5	ПлI	Нет	28.0	3.0	84.0	2.1	15	0	0	0	1	600		3,260
				ПлII	Нет	18.5	3.0	55.5	4.3	15	0	0	0	1	194		
				ПлIII	Нет	41.0	3.0	123.0	8.6	15	0	0	0	1	215		
				Во	Нет	5.5	3.0	16.5	0.5	15	0	0	0	1	495		
				ПлIII	Нет	69.4	10.0	693.7	8.6	15	0	0	0	1	1,210		
														2,713	543	4,340	
Теплопотери на отм. -10.000																	4,340
Этаж на отм. -7.000																	
2001	eleqtroobis avtomatebis		16	ПлIII	Нет	3.5	3.5	12.3	8.6	26	0	0	0	1	37		1,780
				ПлIII	Нет	6.9	3.5	24.2	8.6	26	0	0	0	1	73		
				Пр	Нет	3.5	6.9	24.2	0.5	26	0	0	0	1	1,256		
															1,366	410	
2002	WC		16	Вс	Нет	3.7	3.5	13.0	0.3	26	0	0	0	1	1,122		3,260
				Пр	Нет	3.7	7.2	26.6	0.5	26	0	0	0	1	1,385		
															2,508	752	
2003	saxanZro tumbos oTaxi		16	Нс	З	7.5	3.5	26.3	0.3	26	0.05	0	0	1.05	2,389		4,140
				Нс	Ю	1.7	3.5	6.0	0.3	26	0	0	0	1	516		
				ПлI	Нет	7.5	3.0	22.5	2.1	26	0	0	0	1	279		
															3,183	955	
2004	rezervuarebis saTavsi		16	Нс	Ю	3.5	3.5	12.3	0.3	26	0	0	0	1	1,062		1,690
				ПлI	Нет	3.5	5.5	19.3	2.1	26	0	0	0	1	238		
															1,300	390	
2005	saxanZro tumbos oTaxi		16	Нс	В	8.5	3.5	29.8	0.3	26	0.1	0	0	1.1	2,836		15,010
				Нс	Ю	14.0	3.5	49.0	0.3	26	0	0	0	1	4,247		
				Нс	Нет	8.7	3.5	30.5	0.3	26	0	0	0	1	2,639		
				ПлII	Нет	8.5	13.0	110.5	4.3	26	0	0	0	1	668		
				По	Нет	8.5	13.0	110.5	2.5	26	0	0	0	1	1,149		
															11,539	3,462	
2006			20	ПлII	Нет	44.8	3.5	156.8	4.3	30	0	0	0	1	1,094		66,230
				Нс	В	18.5	3.5	59.8	0.3	30	0.1	0	0	1.1	6,580		
				Нс	Ю	18.0	3.5	38.4	0.3	30	0	0	0	1	3,835		
				Ок1	В	1.7	2.9	4.9	0.5	30	0.1	0	0	1.1	325		
				Ок1	Ю	8.5	2.9	24.7	0.5	30	0	0	0	1	1,479		
				Пр	Нет	44.8	14.0	627.2	0.5	30	0	0	0	1	37,632		
															50,946	15,284	
Теплопотери на отм. -7.000																	92,110

Этаж на отм. -3.500

3001	kiravdeba parti	20	Нс	С	24.0	3.5	76.7	0.3	30	0.1	0	0	1.1	8,437			
			Нс	В	20.0	3.5	17.4	0.3	30	0.1	0	0	1.1	1,917			
			Нс	Ю	41.0	3.5	33.3	0.3	30	0	0	0	1	3,330			
			Пл	Нет	42.0	3.5	147.0	2.1	30	0	0	0	1	2,100			
			Ок1	С	7.3	1.0	7.3	0.5	30	0.1	0	0	1.1	482			
			Ок1	В	18.1	2.9	52.6	0.5	30	0.1	0	0	1.1	3,470			
			Ок1	Ю	38.0	2.9	110.2	0.5	30	0	0	0	1	6,612			
			Пр	Нет	7.3	5.3	38.7	0.5	30	0	0	0	1	2,321			
													28,669	8,601	37,270		
3002	sawyobi	16	Нс	З	8.0	3.5	28.0	0.3	26	0.05	0	0	1.05	2,548			
			Нс	Ю	5.3	3.5	18.6	0.3	26	0	0	0	1	1,608			
			Нс	В	7.5	3.5	26.3	0.3	26	0.1	0	0	1.1	2,503			
			По	Нет	8.5	5.0	42.5	2.5	26	0	0	0	1	442			
													7,100	2,130	9,240		

Теплопотери на отм. -3.500

46,510

Этаж на отм. 0.000

4001	kiravdeba parti	20	Нс	С	50.0	4.0	59.4	0.3	30	0.1	0	0	1.1	6,534			
			Нс	В	20.0	4.0	7.8	0.3	30	0.1	0	0	1.1	864			
			Нс	Ю	50.0	4.0	60.9	0.3	30	0	0	0	1	6,088			
			Нс	З	20.0	4.0	70.4	0.3	30	0.05	0	0	1.05	7,395			
			Ок1	С	38.0	3.7	140.6	0.5	30	0.1	0	0	1.1	9,280			
			Ок1	В	19.5	3.7	72.2	0.5	30	0.1	0	0	1.1	4,762			
			Ок1	Ю	37.6	3.7	139.1	0.5	30	0	0	0	1	8,347			
			Ок1	З	2.9	3.3	9.6	0.5	30	0.05	0	0	1.05	603			
Пр	Нет	15.0	2.0	30.0	0.5	30	0	0	0	1	1,800						
													45,672	13,702	59,380		

Теплопотери на отм. 0.000

59,380

Этаж на отм. +4.000

5001	qarTuli eTnografiuli sivrce	20	Нс	С	36.0	3.3	18.7	0.3	30	0.1	0	0	1.1	2,057			
			Нс	В	22.0	3.3	15.0	0.3	30	0.1	0	0	1.1	1,651			
			Нс	Ю	50.0	3.3	53.2	0.3	30	0	0	0	1	5,320			
			Нс	З	18.5	3.3	52.0	0.3	30	0.05	0	0	1.05	5,455			
			Ок1	С	38.5	2.6	100.1	0.5	30	0.1	0	0	1.1	6,607			
			Ок1	В	22.2	2.6	57.6	0.5	30	0.1	0	0	1.1	3,801			
			Ок1	Ю	43.0	2.6	111.8	0.5	30	0	0	0	1	6,708			
			Ок1	З	3.5	2.6	9.1	0.5	30	0.05	0	0	1.05	573			
													32,172	9,652	41,830		
5002	samzareulo	20	Нс	С	14.5	3.3	12.8	0.3	30	0.1	0	0	1.1	1,403			
			Нс	З	3.5	3.3	11.6	0.3	30	0.05	0	0	1.05	1,213			
			Ок1	С	13.5	2.6	35.1	0.5	30	0.1	0	0	1.1	2,317			
													4,932	1,480	6,420		

Теплопотери на отм. +4.000

48,250

Этаж на отм. +7.300

6001	qarTuli eTnografiuli sivrce	20	Нс	С	36.0	3.3	18.7	0.3	30	0.1	0	0	1.1	2,057			
			Нс	В	22.0	3.3	15.0	0.3	30	0.1	0	0	1.1	1,651			
			Нс	Ю	50.0	3.3	53.2	0.3	30	0	0	0	1	5,320			
			Нс	З	18.5	3.3	52.0	0.3	30	0.05	0	0	1.05	5,455			
			Ок1	С	38.5	2.6	100.1	0.5	30	0.1	0	0	1.1	6,607			
			Ок1	В	22.2	2.6	57.6	0.5	30	0.1	0	0	1.1	3,801			
			Ок1	Ю	43.0	2.6	111.8	0.5	30	0	0	0	1	6,708			
			Ок1	З	3.5	2.6	9.1	0.5	30	0.05	0	0	1.05	573			
													32,172	9,652	41,830		
6002	samzareulo	20	Нс	С	14.5	3.3	12.8	0.3	30	0.1	0	0	1.1	1,403			
			Нс	З	3.5	3.3	11.6	0.3	30	0.05	0	0	1.05	1,213			
			Ок1	С	13.5	2.6	35.1	0.5	30	0.1	0	0	1.1	2,317			
													4,932	1,480	6,420		

Теплопотери на отм. +7.300

48,250

Этаж на отм. -3.500

3001	kiravdeba parti	20	Нс	С	24.0	3.5	76.7	0.3	30	0.1	0	0	1.1	8,437			
			Нс	В	20.0	3.5	17.4	0.3	30	0.1	0	0	1.1	1,917			
			Нс	Ю	41.0	3.5	33.3	0.3	30	0	0	0	1	3,330			
			Пл	Нет	42.0	3.5	147.0	2.1	30	0	0	0	1	2,100			
			Ок1	С	7.3	1.0	7.3	0.5	30	0.1	0	0	1.1	482			
			Ок1	В	18.1	2.9	52.6	0.5	30	0.1	0	0	1.1	3,470			
			Ок1	Ю	38.0	2.9	110.2	0.5	30	0	0	0	1	6,612			
			Пр	Нет	7.3	5.3	38.7	0.5	30	0	0	0	1	2,321			
													28,669	8,601	37,270		
3002	sawyobi	16	Нс	З	8.0	3.5	28.0	0.3	26	0.05	0	0	1.05	2,548			
			Нс	Ю	5.3	3.5	18.6	0.3	26	0	0	0	1	1,608			
			Нс	В	7.5	3.5	26.3	0.3	26	0.1	0	0	1.1	2,503			
			По	Нет	8.5	5.0	42.5	2.5	26	0	0	0	1	442			
													7,100	2,130	9,240		

Теплопотери на отм. -3.500 **46,510**

Этаж на отм. 0.000

4001	kiravdeba parti	20	Нс	С	50.0	4.0	59.4	0.3	30	0.1	0	0	1.1	6,534			
			Нс	В	20.0	4.0	7.8	0.3	30	0.1	0	0	1.1	864			
			Нс	Ю	50.0	4.0	60.9	0.3	30	0	0	0	1	6,088			
			Нс	З	20.0	4.0	70.4	0.3	30	0.05	0	0	1.05	7,395			
			Ок1	С	38.0	3.7	140.6	0.5	30	0.1	0	0	1.1	9,280			
			Ок1	В	19.5	3.7	72.2	0.5	30	0.1	0	0	1.1	4,762			
			Ок1	Ю	37.6	3.7	139.1	0.5	30	0	0	0	1	8,347			
			Ок1	З	2.9	3.3	9.6	0.5	30	0.05	0	0	1.05	603			
			Пр	Нет	15.0	2.0	30.0	0.5	30	0	0	0	1	1,800			
													45,672	13,702	59,380		

Теплопотери на отм. 0.000 **59,380**

Этаж на отм. +4.000

5001	qarTuli eTnografiuli sivrce	20	Нс	С	36.0	3.3	18.7	0.3	30	0.1	0	0	1.1	2,057			
			Нс	В	22.0	3.3	15.0	0.3	30	0.1	0	0	1.1	1,651			
			Нс	Ю	50.0	3.3	53.2	0.3	30	0	0	0	1	5,320			
			Нс	З	18.5	3.3	52.0	0.3	30	0.05	0	0	1.05	5,455			
			Ок1	С	38.5	2.6	100.1	0.5	30	0.1	0	0	1.1	6,607			
			Ок1	В	22.2	2.6	57.6	0.5	30	0.1	0	0	1.1	3,801			
			Ок1	Ю	43.0	2.6	111.8	0.5	30	0	0	0	1	6,708			
			Ок1	З	3.5	2.6	9.1	0.5	30	0.05	0	0	1.05	573			
													32,172	9,652	41,830		

Теплопотери на отм. +4.000 **48,250**

5002	samzareulo	20	Нс	С	14.5	3.3	12.8	0.3	30	0.1	0	0	1.1	1,403			
			Нс	З	3.5	3.3	11.6	0.3	30	0.05	0	0	1.05	1,213			
			Ок1	С	13.5	2.6	35.1	0.5	30	0.1	0	0	1.1	2,317			
													4,932	1,480	6,420		

Теплопотери на отм. +4.000 **48,250**

Этаж на отм. +7.300

6001	qarTuli eTnografiuli sivrce	20	Нс	С	36.0	3.3	18.7	0.3	30	0.1	0	0	1.1	2,057			
			Нс	В	22.0	3.3	15.0	0.3	30	0.1	0	0	1.1	1,651			
			Нс	Ю	50.0	3.3	53.2	0.3	30	0	0	0	1	5,320			
			Нс	З	18.5	3.3	52.0	0.3	30	0.05	0	0	1.05	5,455			
			Ок1	С	38.5	2.6	100.1	0.5	30	0.1	0	0	1.1	6,607			
			Ок1	В	22.2	2.6	57.6	0.5	30	0.1	0	0	1.1	3,801			
			Ок1	Ю	43.0	2.6	111.8	0.5	30	0	0	0	1	6,708			
			Ок1	З	3.5	2.6	9.1	0.5	30	0.05	0	0	1.05	573			
													32,172	9,652	41,830		

Теплопотери на отм. +7.300 **48,250**

6002	samzareulo	20	Нс	С	14.5	3.3	12.8	0.3	30	0.1	0	0	1.1	1,403			
			Нс	З	3.5	3.3	11.6	0.3	30	0.05	0	0	1.05	1,213			
			Ок1	С	13.5	2.6	35.1	0.5	30	0.1	0	0	1.1	2,317			
													4,932	1,480	6,420		

Теплопотери на отм. +7.300 **48,250**

Этаж на отм. +10.600

7001	ucxouri samzareuloebis sivrce	20	Нс	С	36.0	3.3	18.7	0.3	30	0.1	0	0	1.1	2,057		
			Нс	В	22.0	3.3	15.0	0.3	30	0.1	0	0	1.1	1,651		
			Нс	Ю	50.0	3.3	53.2	0.3	30	0	0	0	1	5,320		
			Нс	З	18.5	3.3	52.0	0.3	30	0.05	0	0	1.05	5,455		
			Ок1	С	38.5	2.6	100.1	0.5	30	0.1	0	0	1.1	6,607		
			Ок1	В	22.2	2.6	57.6	0.5	30	0.1	0	0	1.1	3,801		
			Ок1	Ю	43.0	2.6	111.8	0.5	30	0	0	0	1	6,708		
			Ок1	З	3.5	2.6	9.1	0.5	30	0.05	0	0	1.05	573		
			По	Нет	27.0	14.0	378.0	2.5	30	0	0	0	1	4,536		
7002	samzareulo	20	Нс	С	14.5	3.3	12.8	0.3	30	0.1	0	0	1.1	1,403		
			Нс	З	3.5	3.3	11.6	0.3	30	0.05	0	0	1.05	1,213		
			Ок1	С	13.5	2.6	35.1	0.5	30	0.1	0	0	1.1	2,317		
												4,932	1,480	6,420		
Теплопотери на отм. +10.600															54,140	
Этаж на отм. +13.900																
8001	bari/launji	20	Нс	С	26.0	3.3	39.0	0.3	30	0.1	0	0	1.1	4,290		
			Нс	В	15.6	3.3	27.2	0.3	30	0.1	0	0	1.1	2,990		
			Нс	Ю	28.0	3.3	34.7	0.3	30	0	0	0	1	3,468		
			Нс	З	15.6	3.3	51.5	0.3	30	0.05	0	0	1.05	5,405		
			Ок1	С	18.0	2.6	46.8	0.5	30	0.1	0	0	1.1	3,089		
			Ок1	В	8.1	3.0	24.3	0.5	30	0.1	0	0	1.1	1,604		
			Ок1	Ю	22.2	2.6	57.7	0.5	30	0	0	0	1	3,463		
												24,309	7,293	31,610		
Теплопотери на отм. +13.900															31,610	
Этаж на отм. +17.200																
9001	derepani	18	Нс	С	4.3	3.3	12.0	0.3	28	0.1	0	0	1.1	1,231		
			Нс	В	4.2	3.3	11.7	0.3	28	0.1	0	0	1.1	1,197		
			Нс	З	5.5	3.3	18.2	0.3	28	0.05	0	0	1.05	1,779		
			Дв1	С	1.0	2.2	2.2	0.5	28	0.1	5.28	0	6.38	786		
			Дв1	В	1.0	2.2	2.2	0.5	28	0.1	5.28	0	6.38	786		
			По	Нет	6.4	10.0	64.0	2.5	28	0	0	0	1	717		
												6,496	1,949	8,450		
9002	sast'umros otakh	22	Нс	С	5.0	3.3	4.8	0.3	32	0.1	0	0	1.1	563		
			Нс	З	3.3	3.3	10.9	0.3	32	0.05	0	0	1.05	1,220		
			Ок1	С	4.5	2.6	11.7	0.5	32	0.1	0	0	1.1	824		
			По	Нет	2.2	10.0	22.0	2.5	32	0	0	0	1	282		
												2,888	866	3,760		
9003	sashkhap'e	25	По	Нет	5.2	1.0	5.2	2.5	35	0	0	0	1	73		
													73	22	100	
9004	sast'umros otakh	22	Нс	С	7.2	3.3	5.0	0.3	32	0.1	0	0	1.1	591		
			Ок1	С	7.2	2.6	18.7	0.5	32	0.1	0	0	1.1	1,318		
			По	Нет	7.2	4.9	35.3	2.5	32	0	0	0	1	452		
												2,361	708	3,070		
9005	sashkhap'e	25	Нс	С	2.3	3.3	1.6	0.3	35	0.1	0	0	1.1	207		
			Ок1	С	2.3	2.6	6.0	0.5	35	0.1	0	0	1.1	460		
			По	Нет	2.3	2.3	5.3	2.5	35	0	0	0	1	74		
												741	222	970		

9006	loji	20	Нс	С	4.0	3.3	2.8	0.3	30	0.1	0	0	1.1	308	2,460	
			Нс	В	3.2	3.3	1.0	0.3	30	0.1	0	0	1.1	106		
			Ок1	С	4.0	2.6	10.4	0.5	30	0.1	0	0	1.1	686		
			Ок1	В	3.2	3.0	9.6	0.5	30	0.1	0	0	1.1	634		
			По	Нет	4.1	3.2	13.1	2.5	30	0	0	0	1	157		
														1,891	567	
9007	san-kvanZi	18	Нс	Ю	3.8	3.3	9.9	0.3	28	0	0	0	1	928	1,690	
			Ок1	Ю	1.0	2.6	2.6	0.5	28	0	0	0	1	146		
			По	Нет	3.8	5.2	19.8	2.5	28	0	0	0	1	221		
														1,295	388	
9008	sakomferencio	20	Нс	Ю	6.7	3.3	5.0	0.3	30	0	0	0	1	505	2,710	
			Ок1	Ю	6.5	2.6	16.9	0.5	30	0	0	0	1	1,014		
			По	Нет	6.7	7.0	46.6	2.5	30	0	0	0	1	559		
														2,077	623	
9009	k'abinet'i	20	Нс	Ю	3.2	3.3	2.2	0.3	30	0	0	0	1	221	1,290	
			Ок1	Ю	3.2	2.6	8.2	0.5	30	0	0	0	1	491		
			По	Нет	3.2	7.3	23.0	2.5	30	0	0	0	1	276		
														988	296	
9010	k'abinet'i	20	Нс	Ю	11.3	3.3	6.1	0.3	30	0	0	0	1	611	6,400	
			Нс	В	5.4	3.3	2.4	0.3	30	0.1	0	0	1.1	259		
			Нс	З	1.2	3.3	4.0	0.3	30	0.05	0	0	1.05	416		
			Ок1	Ю	3.8	2.6	9.9	0.5	30	0	0	0	1	593		
			Ок1	Ю	7.1	3.0	21.3	0.5	30	0	0	0	1	1,278		
			Ок1	В	5.1	3.0	15.3	0.5	30	0.1	0	0	1.1	1,010		
			По	Нет	6.3	10.0	63.0	2.5	30	0	0	0	1	756		
														4,922	1,477	
														Теплопотери на отм. +17.200		30,900
Этаж на отм. +20.500																
9001	liftis teqnikuri oTaxi	16	Нс	С	4.5	3.3	12.7	0.3	26	0.1	0	0	1.1	1,206	8,720	
			Нс	В	6.1	3.3	17.9	0.3	26	0.1	0	0	1.1	1,709		
			Нс	З	6.0	3.3	19.8	0.3	26	0.05	0	0	1.05	1,802		
			Дв1	С	1.0	2.2	2.2	0.5	26	0.1	5.28	0	6.38	730		
			Дв1	В	1.0	2.2	2.2	0.5	26	0.1	5.28	0	6.38	730		
			По	Нет	5.1	10.0	51.0	2.5	26	0	0	0	1	530		
														6,707	2,012	
														Теплопотери на отм. +17.200		8,720
														Теплопотери здания:		424,210

75.9 Вт/м²

Условные обозначения

- Параметры для выбора из выпадающего списка
- Параметры заполняемые автоматически
- Параметры заполняемые автоматически, но допускающие ручной ввод
- Параметры для ручного ввода

№ п/п	Назначение	Площадь	Высота	Объем	Кол-во людей	Теплопоступления от людей (полные)			Теплопоступления от оборудования				Теплопоступления от искусственного освещения		Теплопоступления от солнечной радиации						Учитывать совместное действие СР и искусственного освещения	Пиковый теплоприток по помещениям, Вт	теплопритоки от ограждающих конструкций	Итого				
						Кат. Работ	qл	Qл	Тип оборуду-ния	Кол-во шт.	qоб, Вт/ед	Qоб Вт	qосв Вт/чел	Qосв Вт	Обозначение ограждения	Кол-во	Ориентация	Ширина, А м	Высота, В м	Площадь м2					Теплоприток от солн.рад	Qрад. сут 5-19ч	Qрад. макс.расч. 9-19	
							Вт/чел	Вт																	18-19			
1	2	3 м2	4 м	5 м3	10 чел.	12	13 Вт/чел	14 Вт	17	18 шт.	19 Вт/ед	20 Вт	23 Вт/чел	24 Вт	25	26	27	28 м	29 м	30 м2	58 18-19	59 5-19ч	60 9-19	61	62	63	64	
101	Отметка -7.000	910	3.5	3185	120	Легкая	146	17520					18	16378	OK2	18	Ю	1.0	2.8	3			12929	нет	33898	40690	74588	
101															OK2	9	В	1.0	2.8	3								
102	Отметка -3.500	872	3.5	3052	115	Легкая	146	16790					18	15696	OK2	39	Ю	1.0	2.8	3			23803	нет	40593	20940	61533	
102															OK2	12	В	1.0	2.8	3								
103	Отметка 0.000	762	4.0	3049	101	Легкая	146	14746					18	13720	OK6	36	С	1.0	3.7	4			42512	нет	57258	27700	84958	
103															OK6	20	В	1.0	3.7	4								
103															OK6	38	Ю	1.0	3.7	4								
104	Отметка +4.000	755	3.3	2492	100	Легкая	146	14600					18	13590	OK1	39	С	1.0	2.6	3			33501	нет	48101	22500	70601	
104															OK1	22	В	1.0	2.6	3								
104															OK1	43	Ю	1.0	2.6	3								
105	Отметка +7.300	755	3.3	2492	100	Легкая	146	14600					18	13590	OK1	39	С	1.0	2.6	3			33501	нет	48101	22500	70601	
105															OK1	22	В	1.0	2.6	3								
105															OK1	43	Ю	1.0	2.6	3								
106	Отметка +10.600	755	3.3	2492	100	Легкая	146	14600					18	13590	OK1	39	С	1.0	2.6	3			33501	нет	48101	25250	73351	
106															OK1	22	В	1.0	2.6	3								
106															OK1	43	Ю	1.0	2.6	3								
107	Отметка +17.200	392	3.3	1294	52	Легкая	146	7592					18	7056	OK1	21	С	1.0	2.6	3			20021	нет	27613	14740	42353	
107															OK4	14	В	1.0	3.0	3								
107															OK1	21	Ю	1.0	2.6	3								
108	Отметка +20.500	392	3.3	1294	52	Легкая	146	7592					18	7056	OK1	21	С	1.0	2.6	3			20021	нет	27613	15564	43177	
108															OK4	14	В	1.0	3.0	3								
108															OK1	21	Ю	1.0	2.6	3								

Вт/м ²	93.2	331278.2	189884.0	521162.2
Вт/м ²	75.8			424210

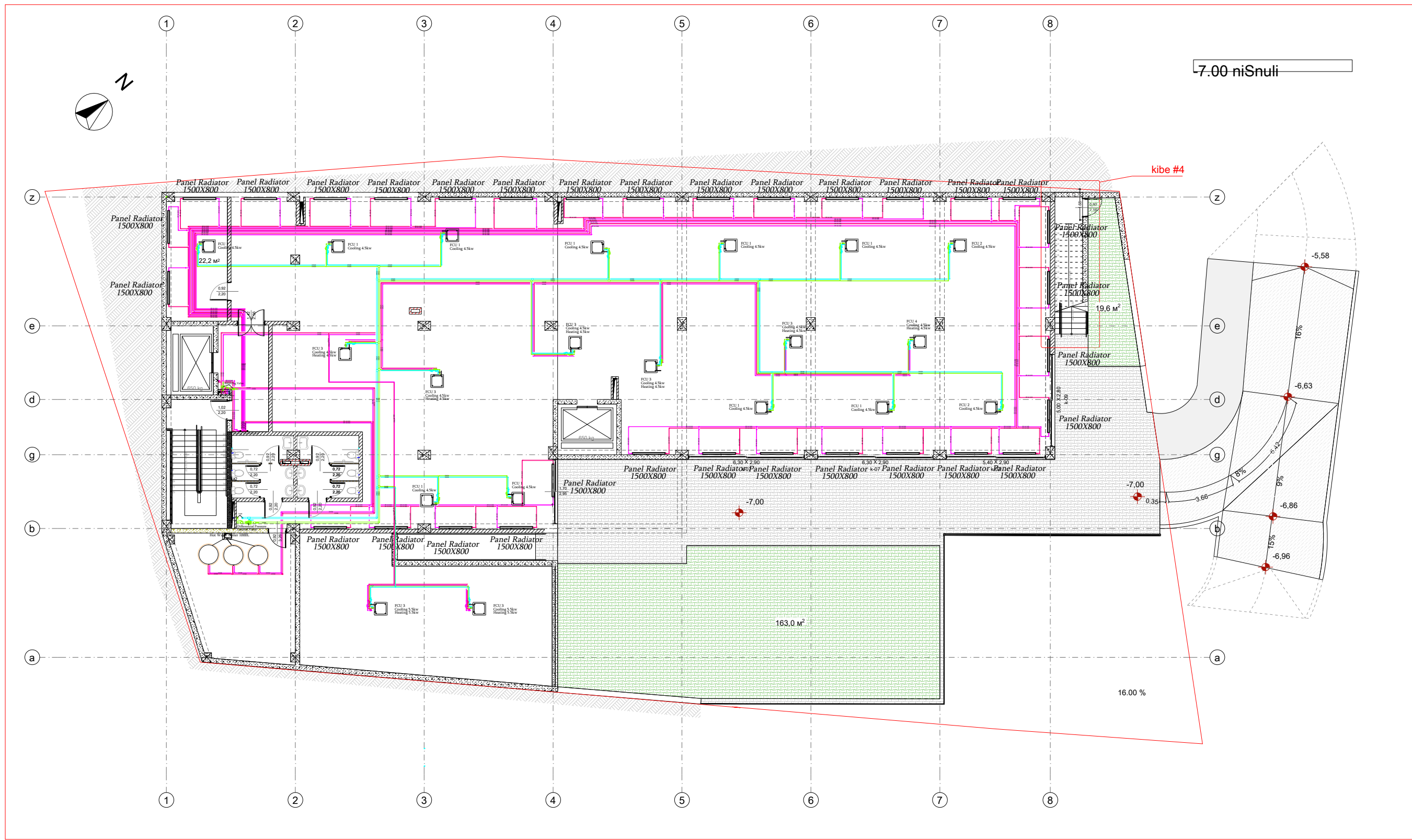

FCU 1 connection scheme

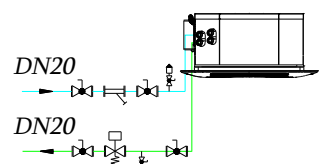

FCU 2 connection scheme

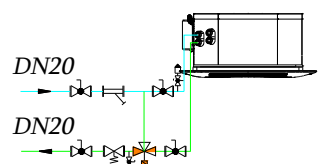

FCU 3 connection scheme

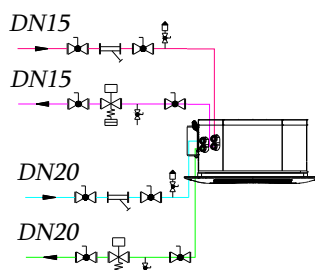



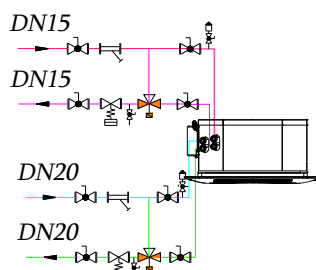



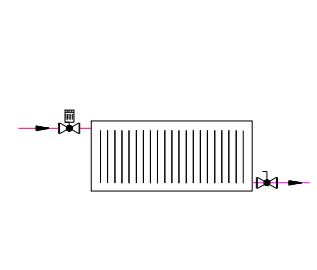



FCU 4 connection scheme



Radiator connection scheme



-  Ball Valve
-  Y-Strainer
-  2-way Pressure independent Balancing and Control Valve with modulating actuator
-  3-Way Valve with electric actuator
-  Balancing Valve
-  Air Valve
-  Thermostatic Valve
-  Cooling Supply
-  Cooling Return
-  Heating Supply
-  Heating Return

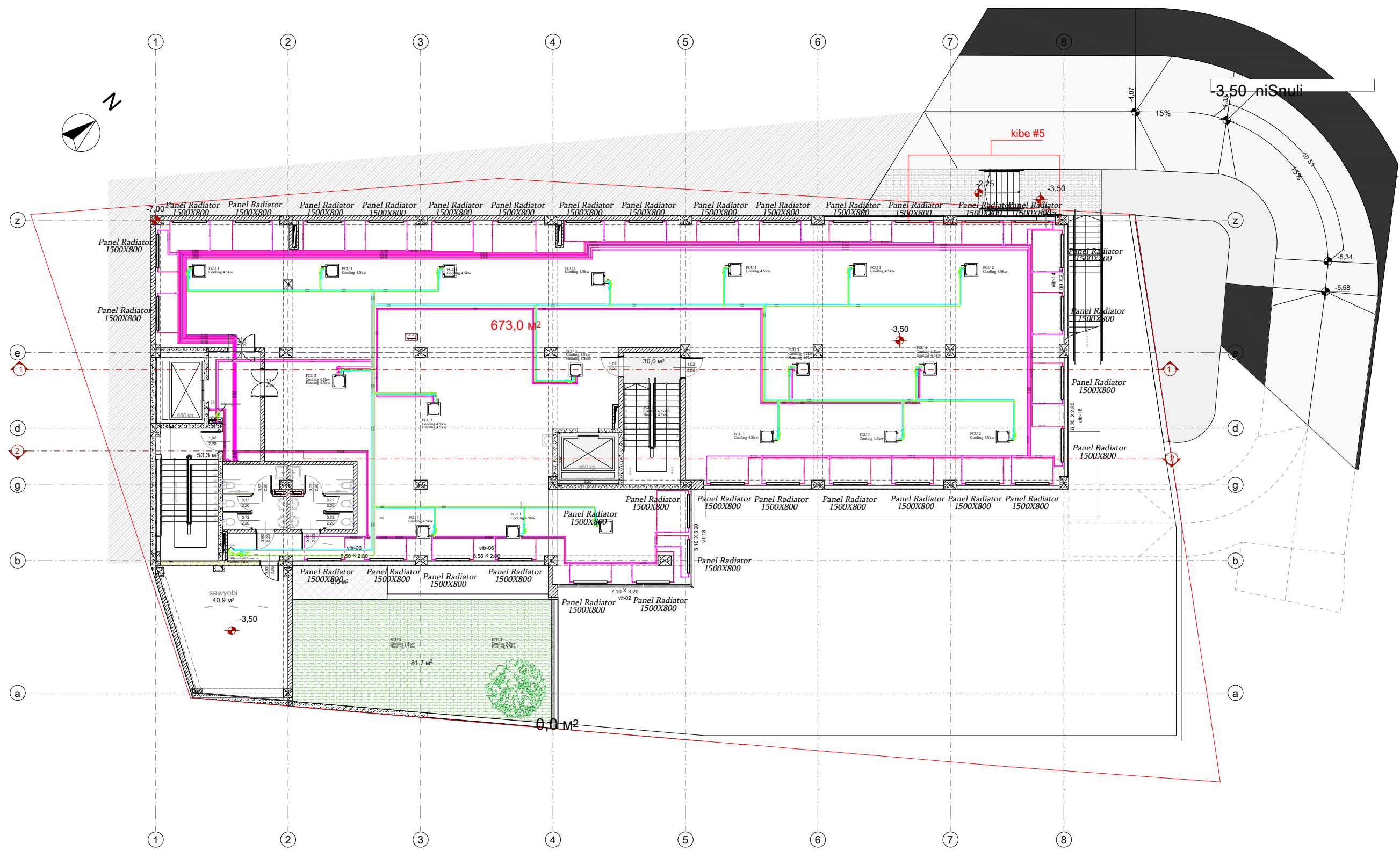

FCU 1 connection scheme

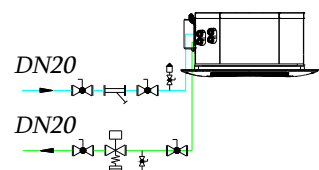

FCU 2 connection scheme

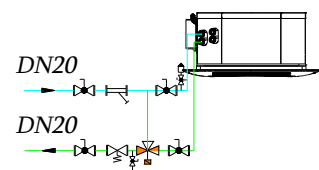

FCU 3 connection scheme

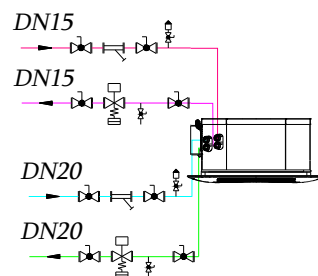



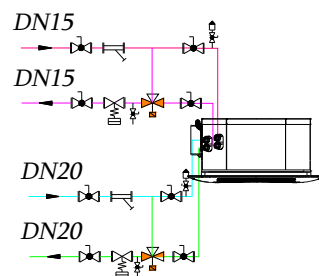



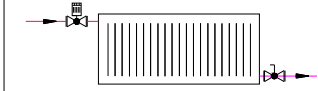



FCU 4 connection scheme



Radiator connection scheme



-  Ball Valve
 -  Y-Strainer
 -  2-way Pressure independent Balancing and Control Valve with modulating actuator
 -  3-Way Valve with electric actuator
 -  Balancing Valve
 -  Air Valve
 -  Thermostatic Valve
-  Cooling Supply
 -  Cooling Return
 -  Heating Supply
 -  Heating Return

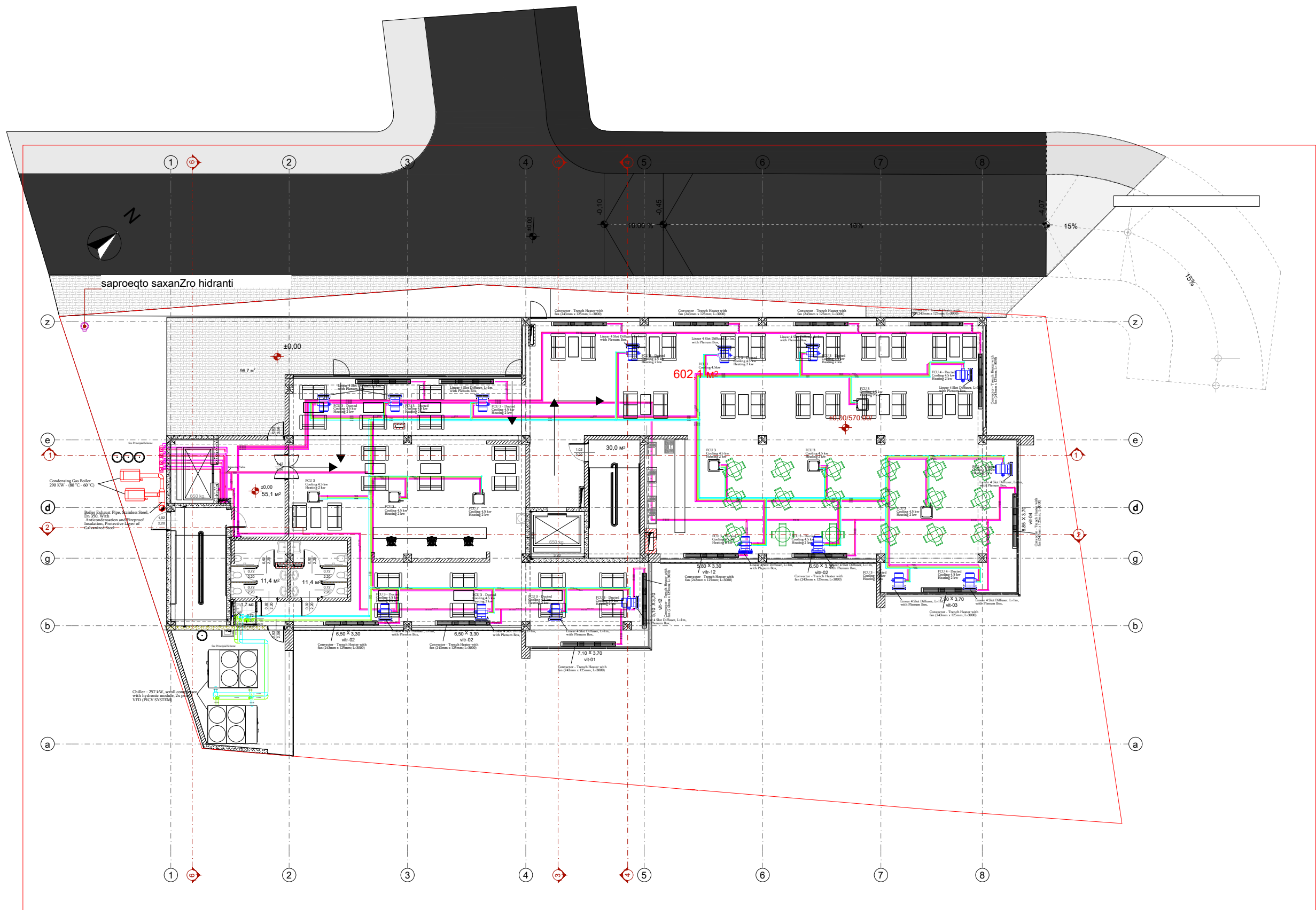

FCU 1 connection scheme

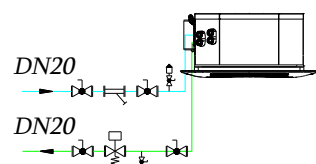

FCU 2 connection scheme

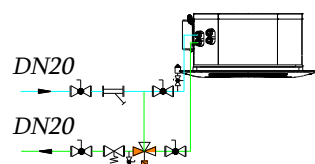

FCU 3 connection scheme

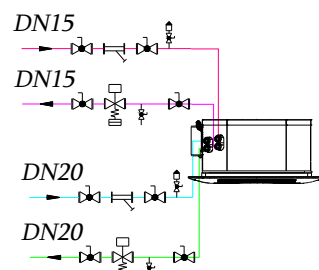

FCU 4 connection scheme

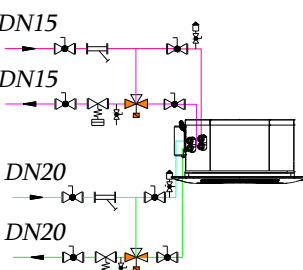

Radiator connection scheme

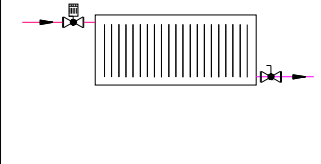

- | | | | |
|--|---|--|----------------|
| | Ball Valve | | Cooling Supply |
| | Y-Strainer | | Cooling Return |
| | 2-way Pressure independent Balancing and Control Valve with modulating actuator | | Heating Supply |
| | 3-Way Valve with electric actuator | | Heating Return |
| | Balancing Valve | | |
| | Air Valve | | |
| | Thermostatic Valve | | |

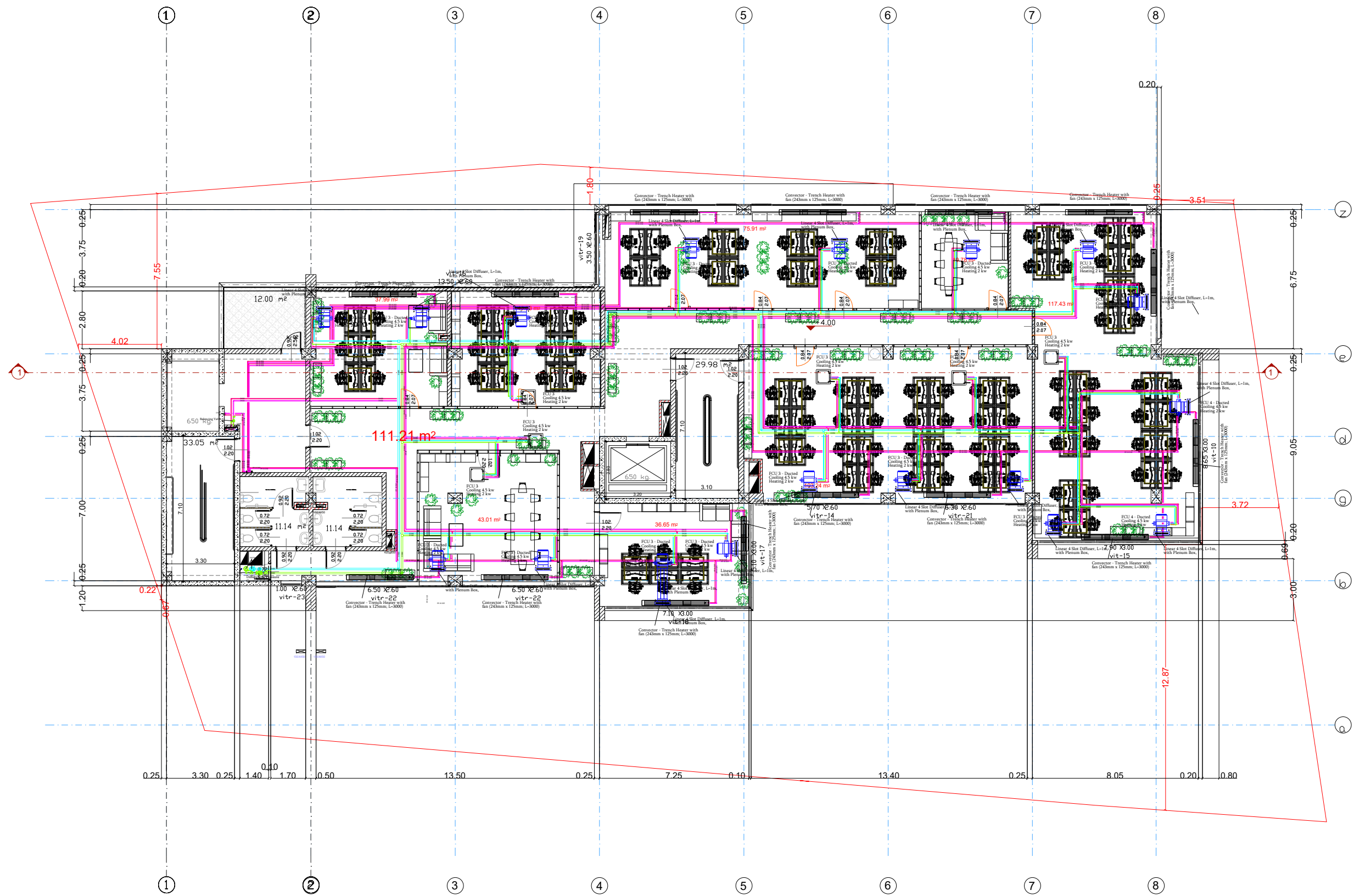

FCU 1 connection scheme

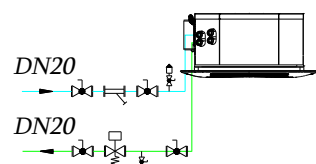

FCU 2 connection scheme

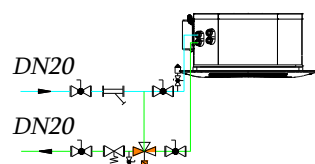

FCU 3 connection scheme

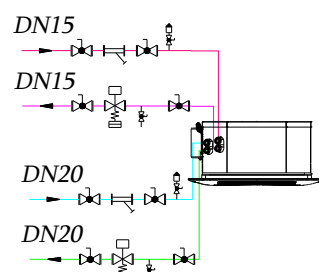



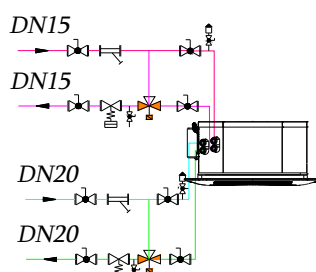



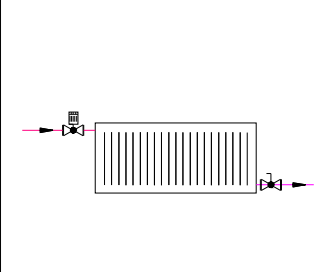



FCU 4 connection scheme



Radiator connection scheme



-  Ball Valve
-  Y-Strainer
-  2-way Pressure independent Balancing and Control Valve with modulating actuator
-  3-Way Valve with electric actuator
-  Balancing Valve
-  Air Valve
-  Thermostatic Valve

-  Cooling Supply
-  Cooling Return
-  Heating Supply
-  Heating Return

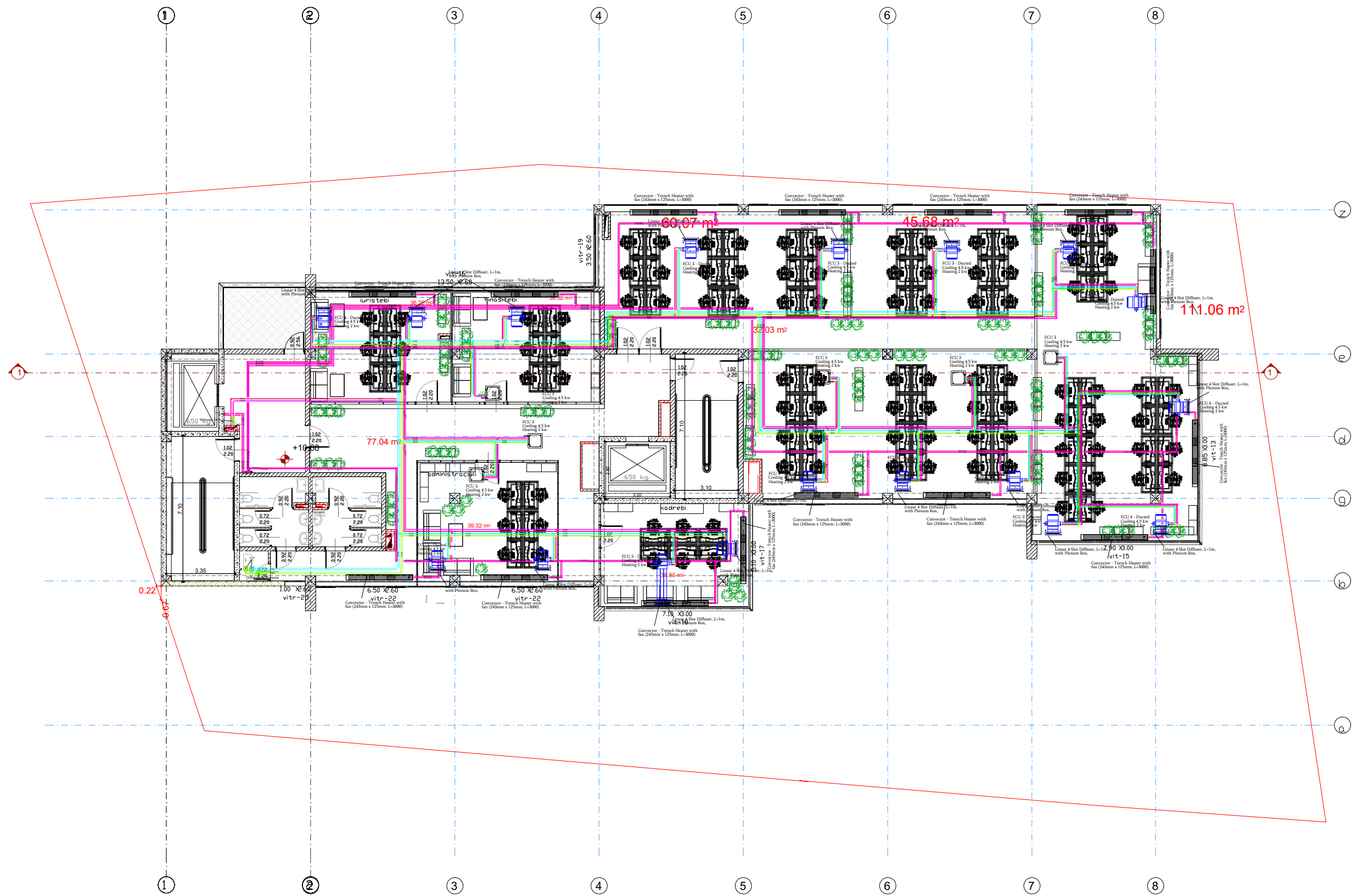

FCU 1 connection scheme

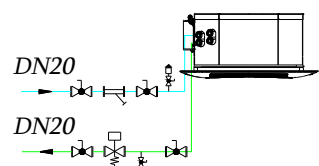

FCU 2 connection scheme

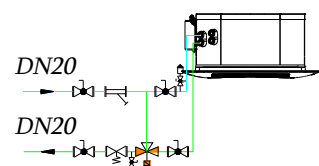

FCU 3 connection scheme

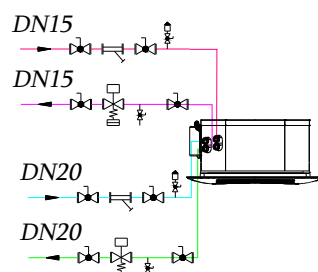

FCU 4 connection scheme

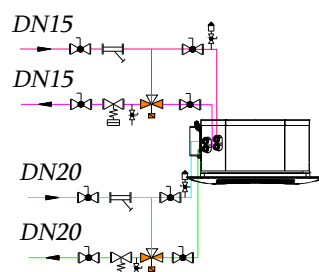

Radiator connection scheme

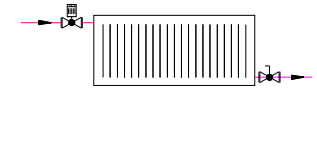

- | | | | |
|--|---|--|----------------|
| | Ball Valve | | Cooling Supply |
| | Y-Strainer | | Cooling Return |
| | 2-way Pressure independent Balancing and Control Valve with modulating actuator | | Heating Supply |
| | 3-Way Valve with electric actuator | | Heating Return |
| | Balancing Valve | | |
| | Air Valve | | |
| | Thermostatic Valve | | |

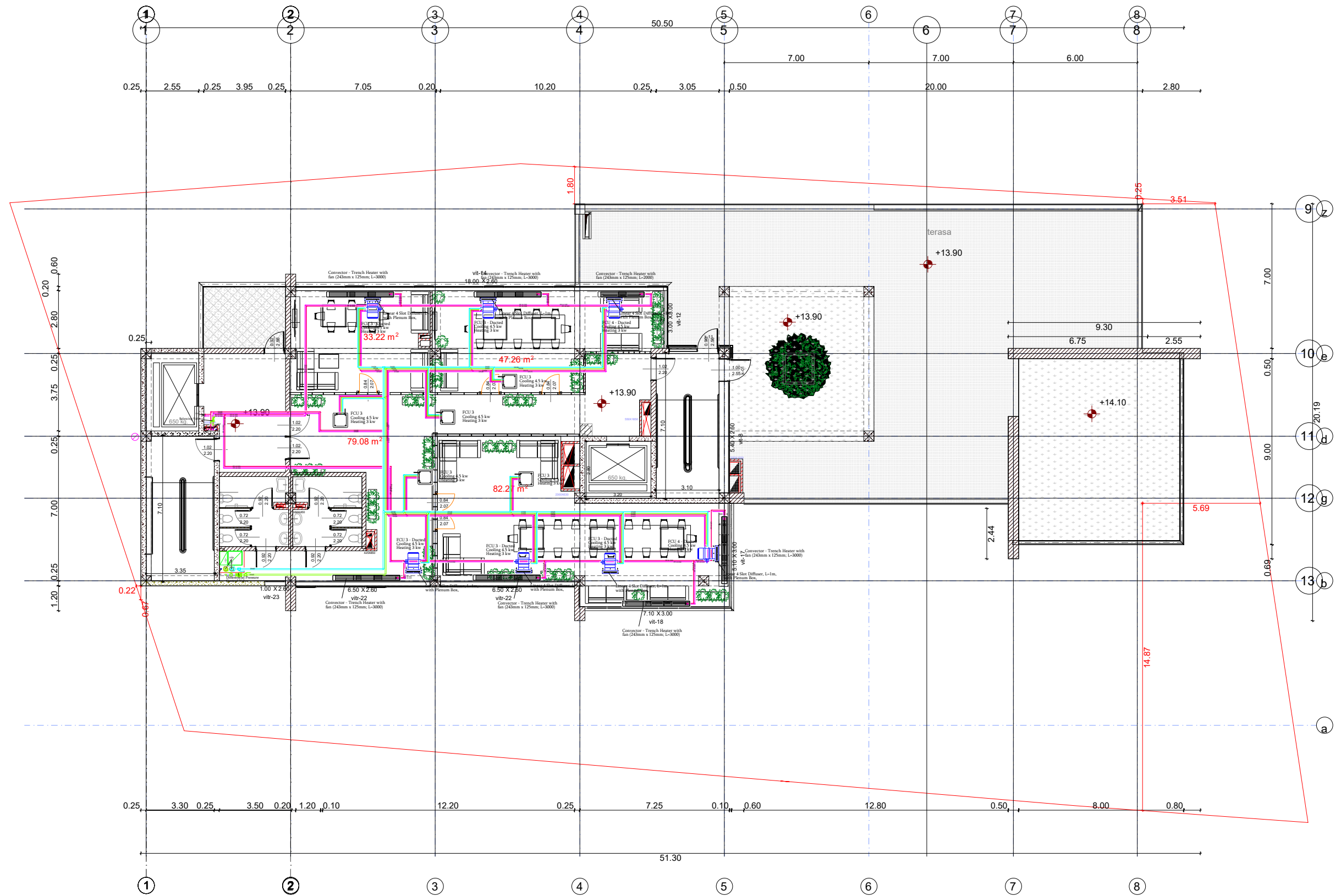

FCU 1 connection scheme

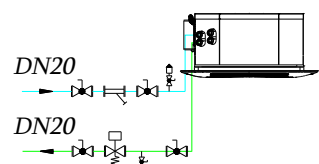

FCU 2 connection scheme

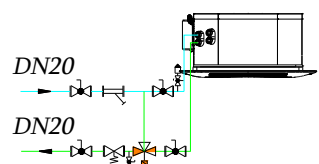

FCU 3 connection scheme

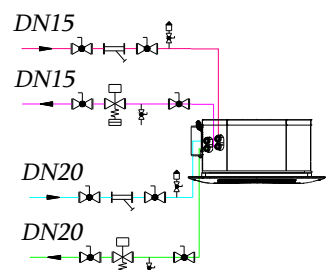



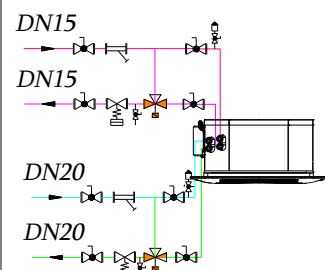



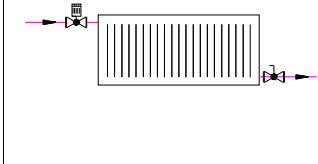



FCU 4 connection scheme



Radiator connection scheme



-  Ball Valve
-  Y-Strainer
-  2-way Pressure independent Balancing and Control Valve with modulating actuator
-  3-Way Valve with electric actuator
-  Balancing Valve
-  Air Valve
-  Thermostatic Valve

-  Cooling Supply
-  Cooling Return
-  Heating Supply
-  Heating Return

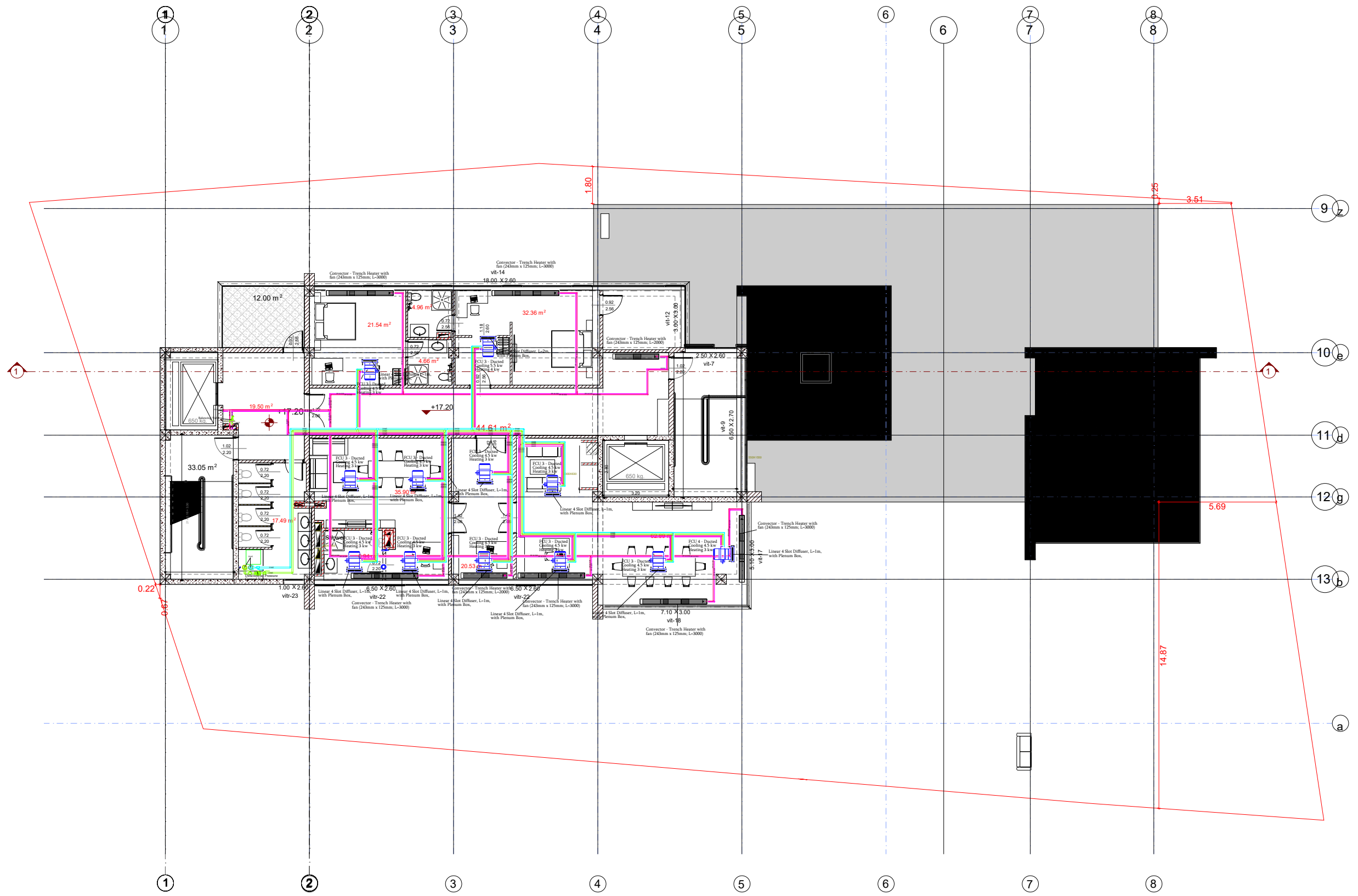

FCU 1 connection scheme

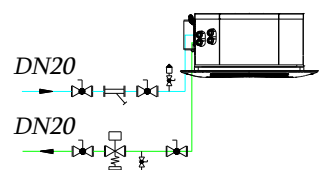

FCU 2 connection scheme

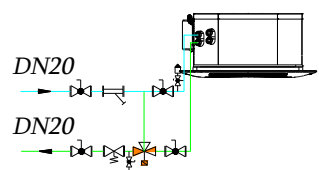

FCU 3 connection scheme

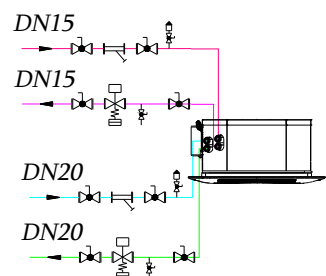

FCU 4 connection scheme

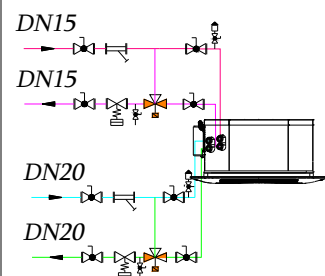

Radiator connection scheme

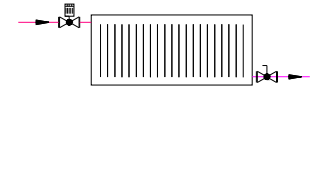



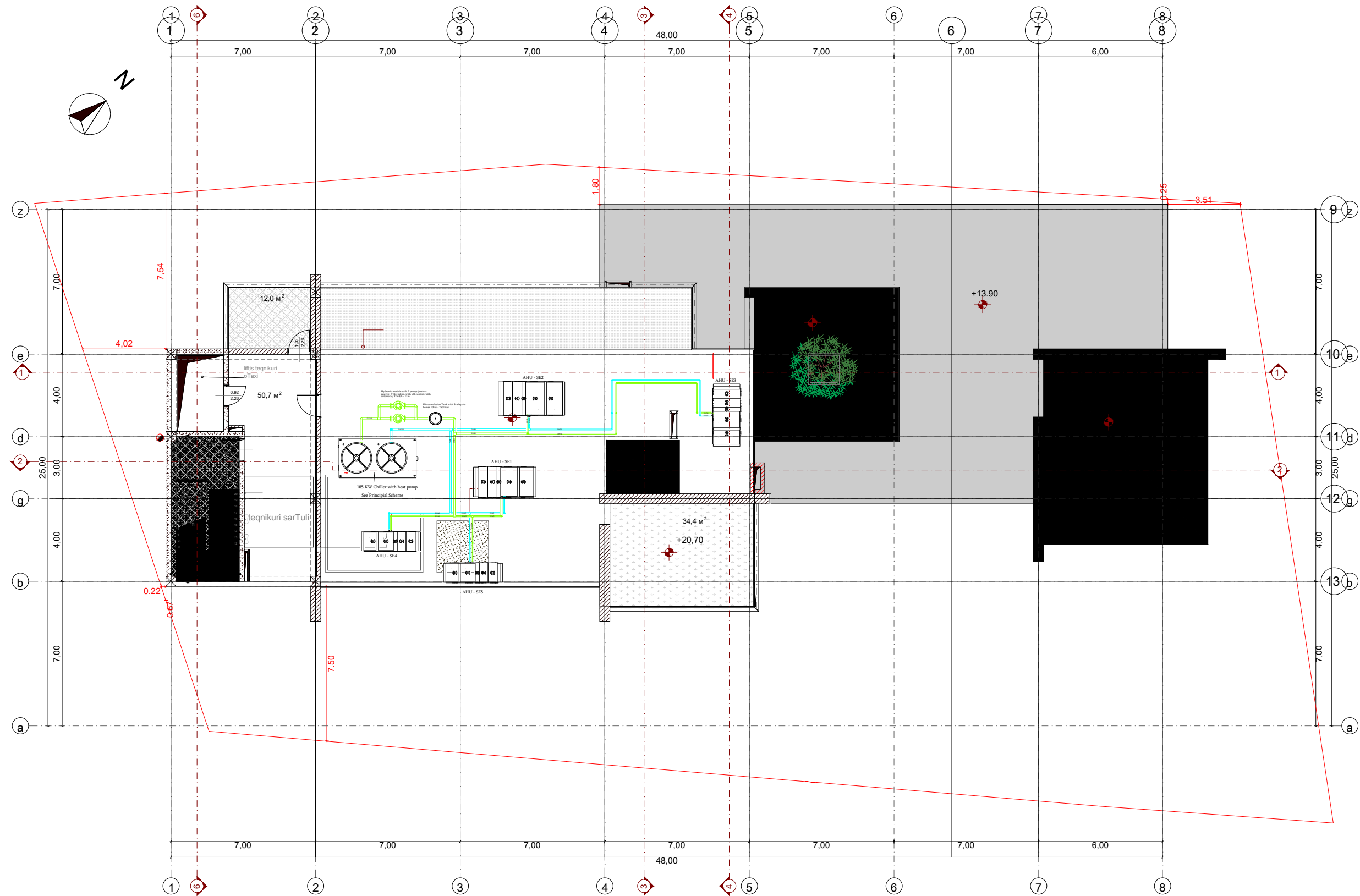



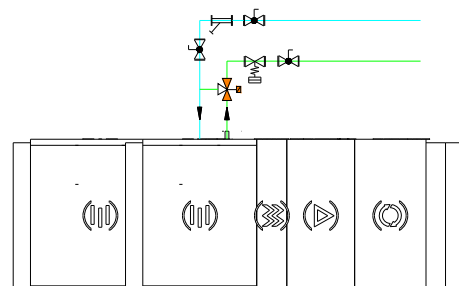

- | | | | |
|--|---|--|----------------|
| | Ball Valve | | Cooling Supply |
| | Y-Strainer | | Cooling Return |
| | 2-way Pressure independent Balancing and Control Valve with modulating actuator | | Heating Supply |
| | 3-Way Valve with electric actuator | | Heating Return |
| | Balancing Valve | | |
| | Air Valve | | |
| | Thermostatic Valve | | |









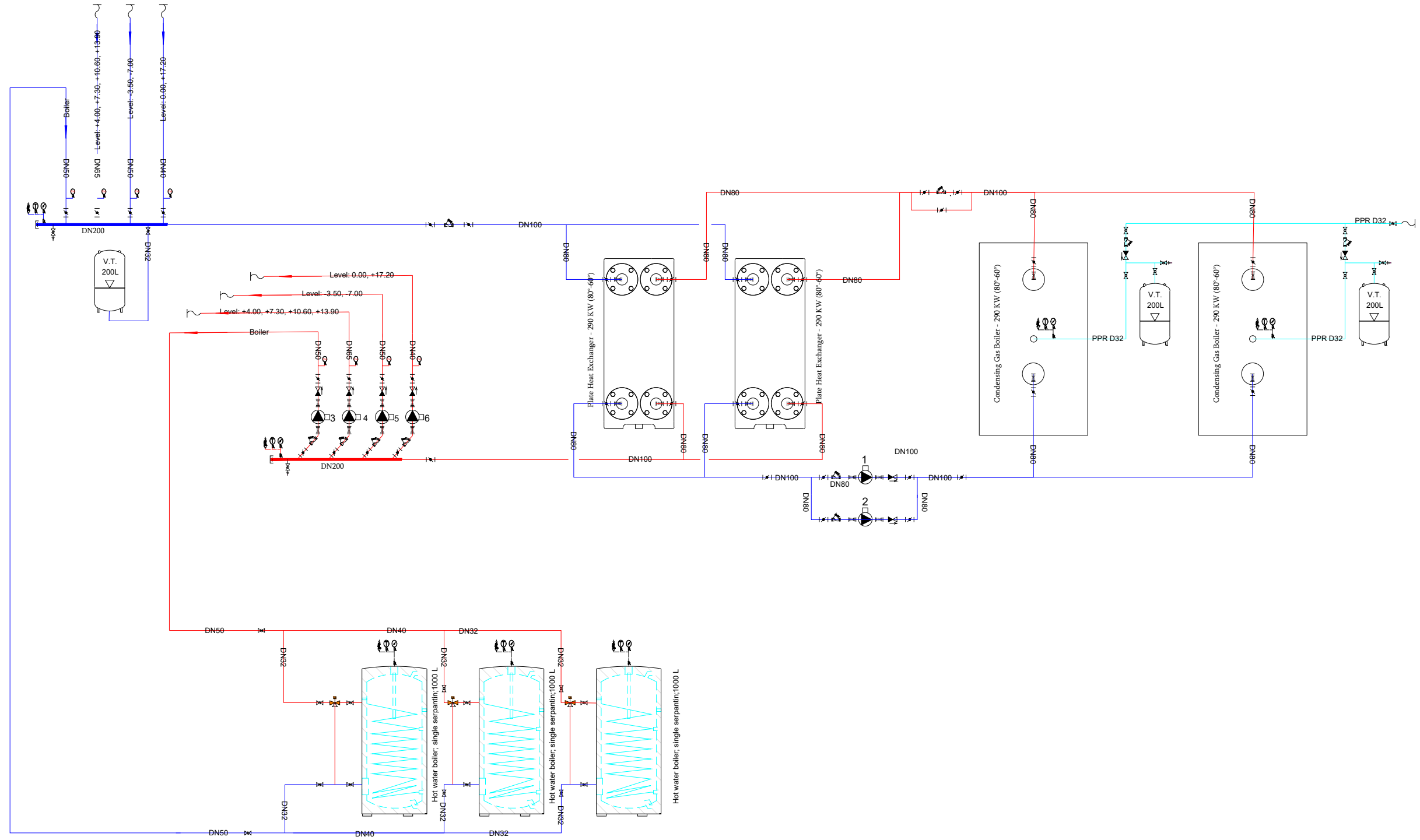







Air Handling Unit Connection Scheme



-  Cooling Supply
-  Cooling Return
-  Heating Supply
-  Heating Return
-  Ball Valve
-  Y-Strainer
-  3-Way Valve with electric actuator
-  Balancing Valve



	Ball Valve		Compensator		Thermo Manometer		1 Inline type pump, VFD L=12.5 m ³ /h; H= 8 m
	Gate Valve		3-Way Motorised Valve		Y-Strainer		2 Inline type pump, VFD L=12.5 m ³ /h; H= 8 m
	Check Valve		Safety Group		Volume Tank		3 Circulation pump, VFD L=6.56 m ³ /h; H= 15 m
							4 Circulation pump, VFD L=7.81 m ³ /h; H= 14 m
							5 Circulation pump, VFD L=5.94 m ³ /h; H= 14 m
							6 Circulation pump, VFD L=13.87 m ³ /h; H= 14 m

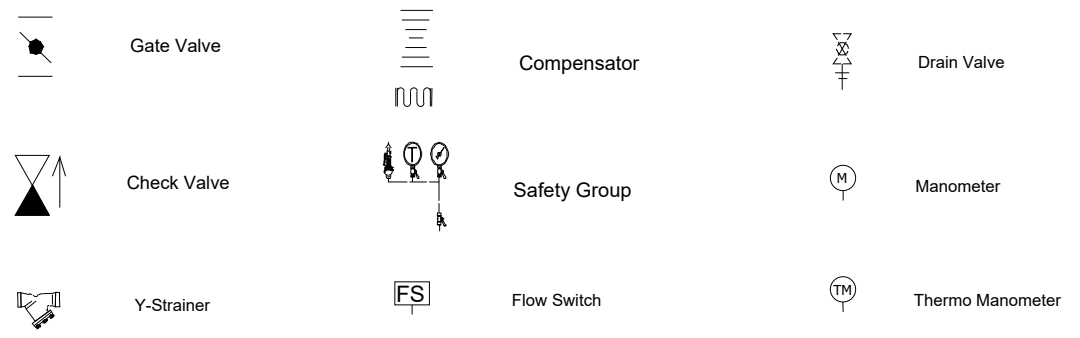
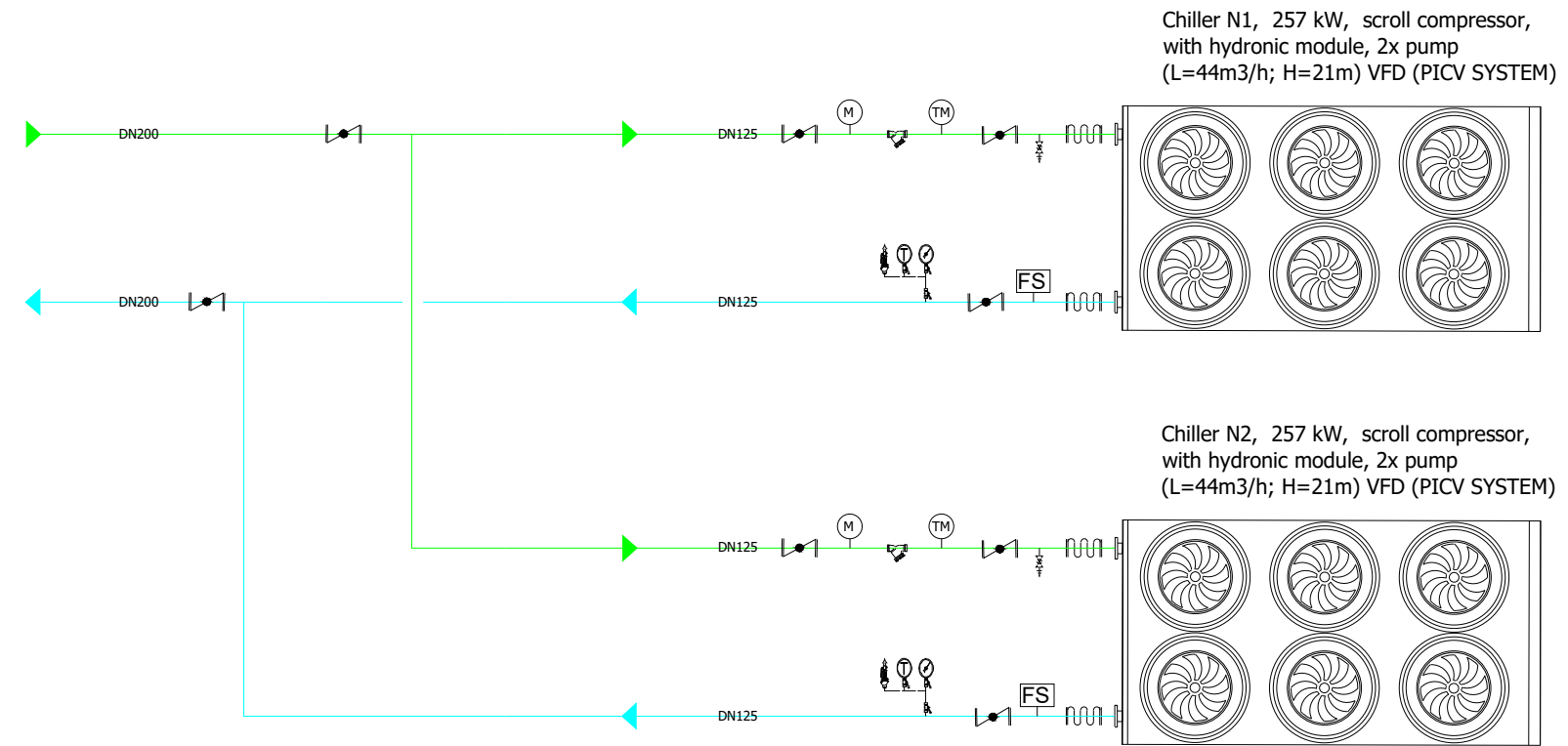
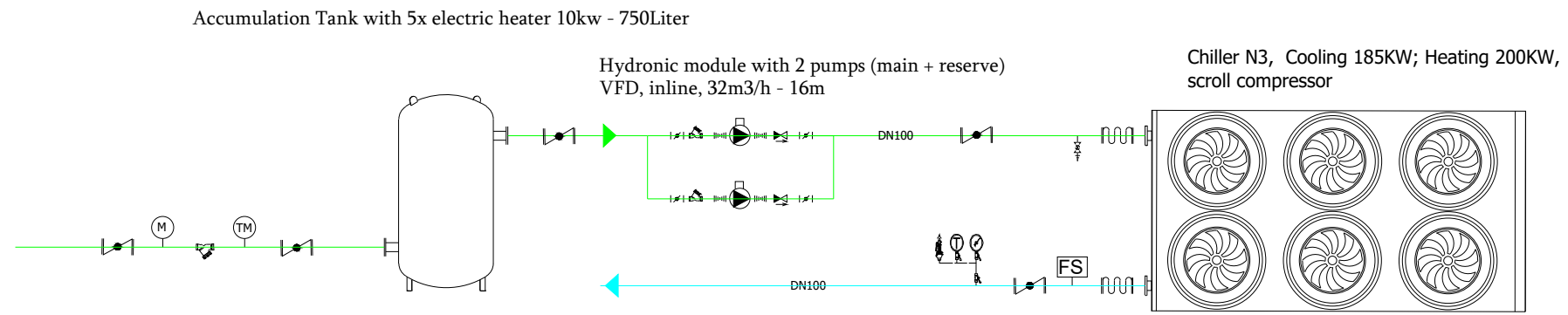

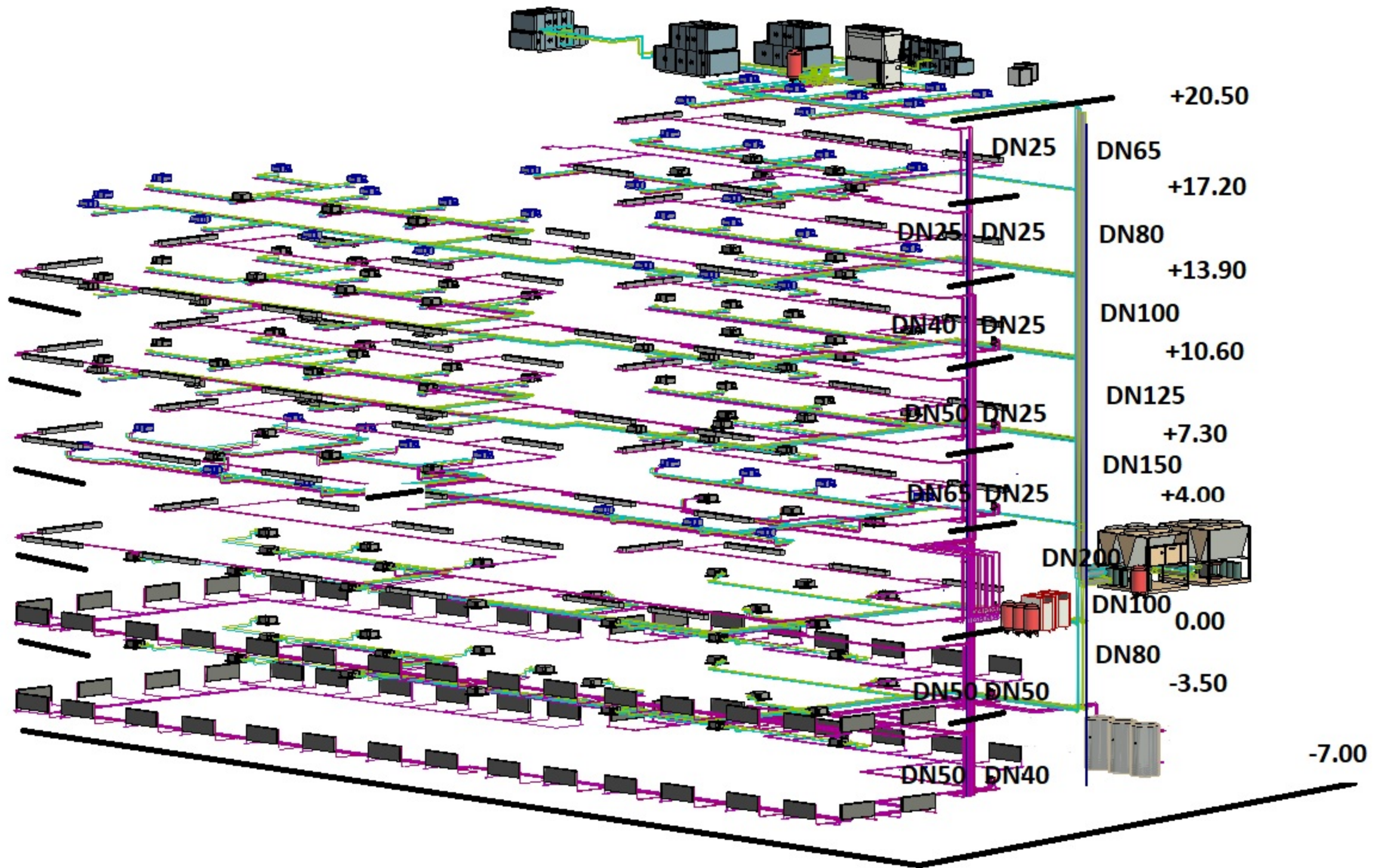

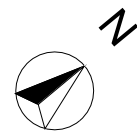

7.00 niSnuli

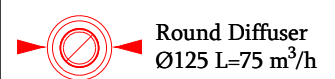
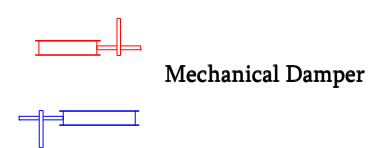
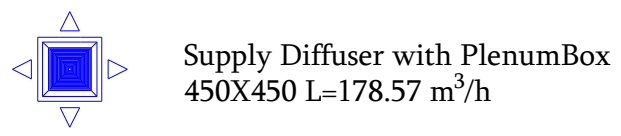
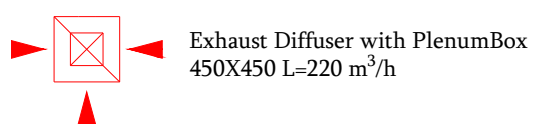
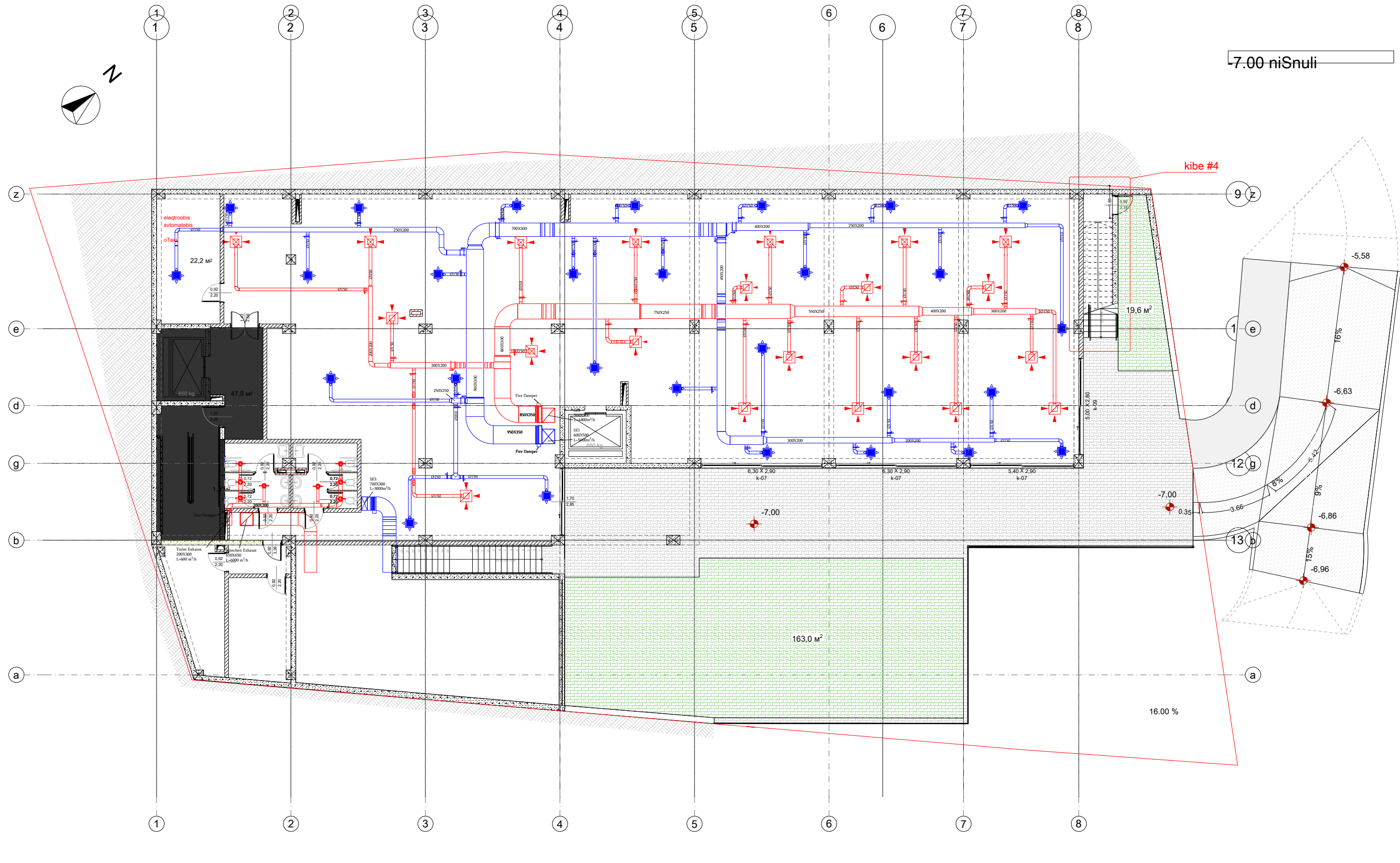

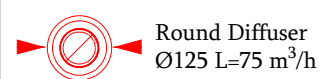
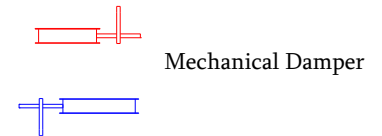
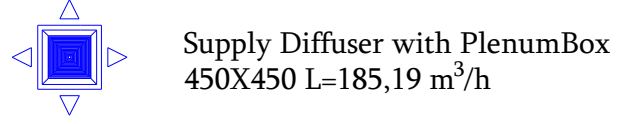
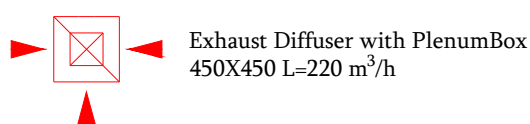
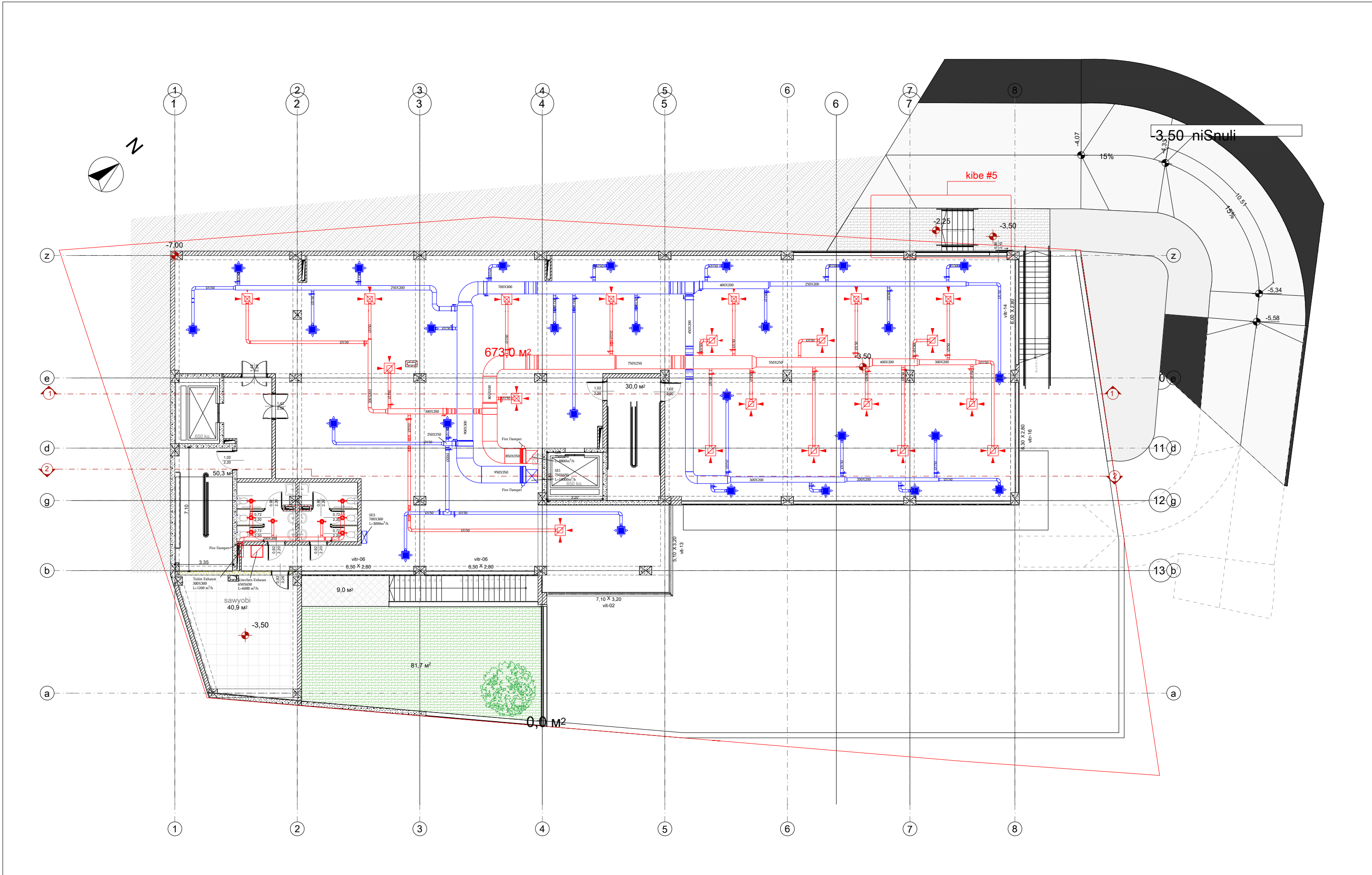

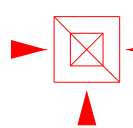
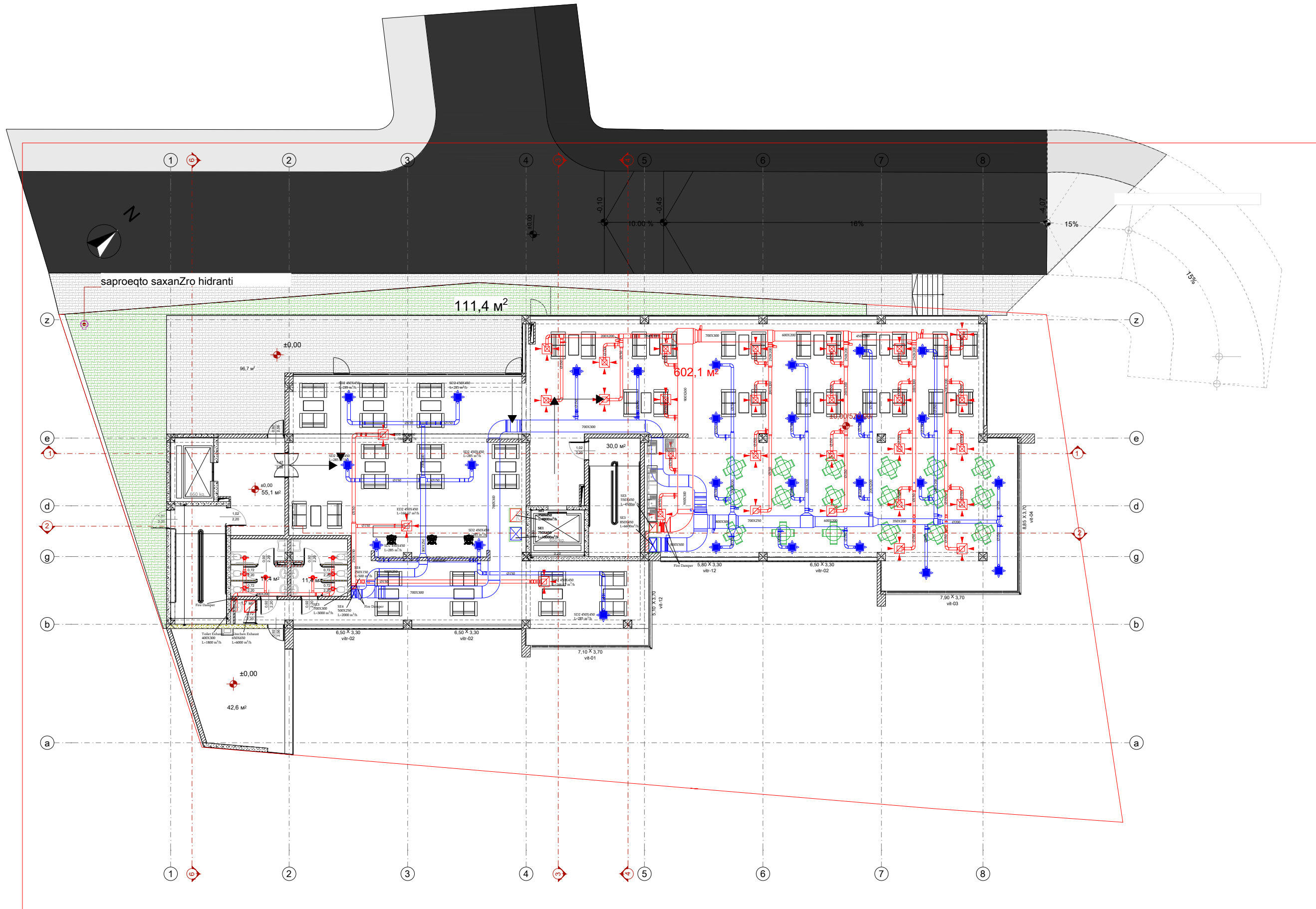

Exhaust Diffuser with PlenumBox
450X450 L=173.08 m³/h

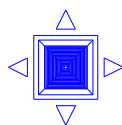

Supply Diffuser with PlenumBox
450X450 L=180 m³/h

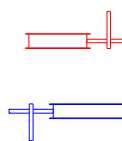

Mechanical Damper



Round Diffuser
Ø125 L=75 m³/h

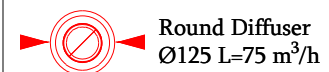
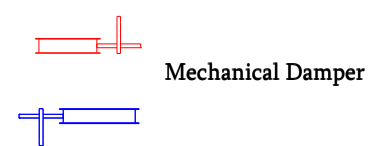
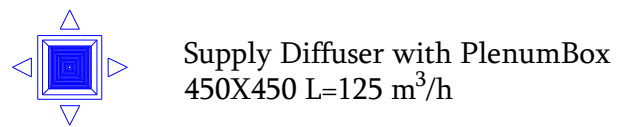
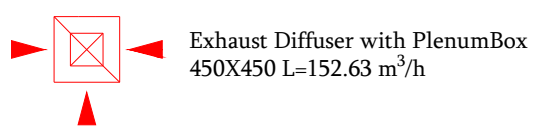
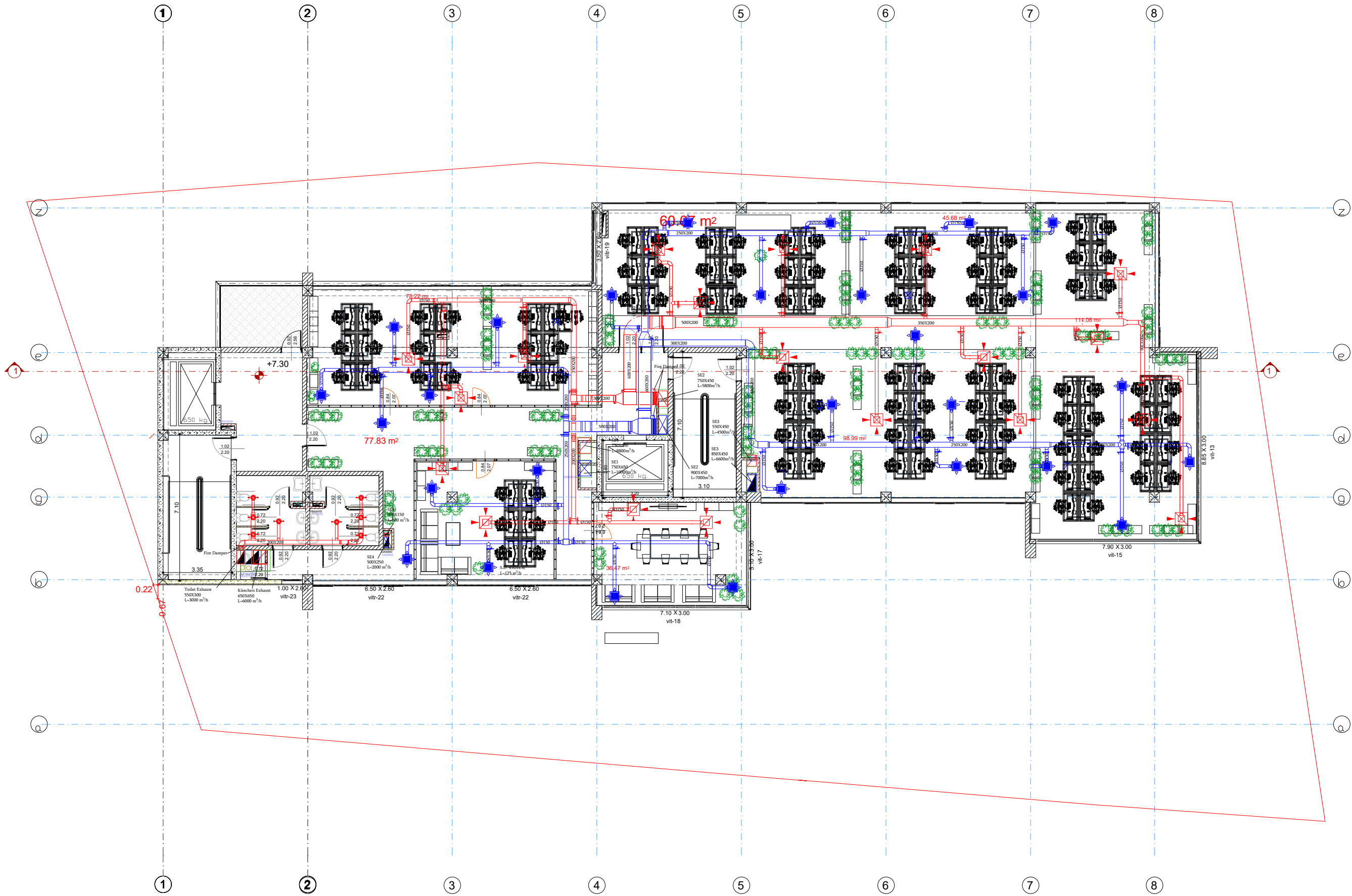

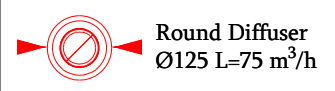
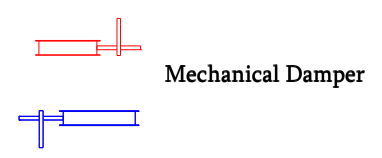
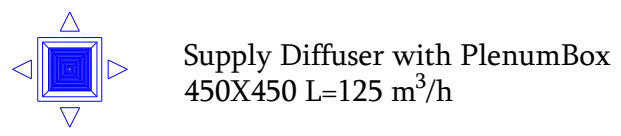
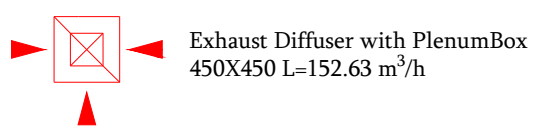
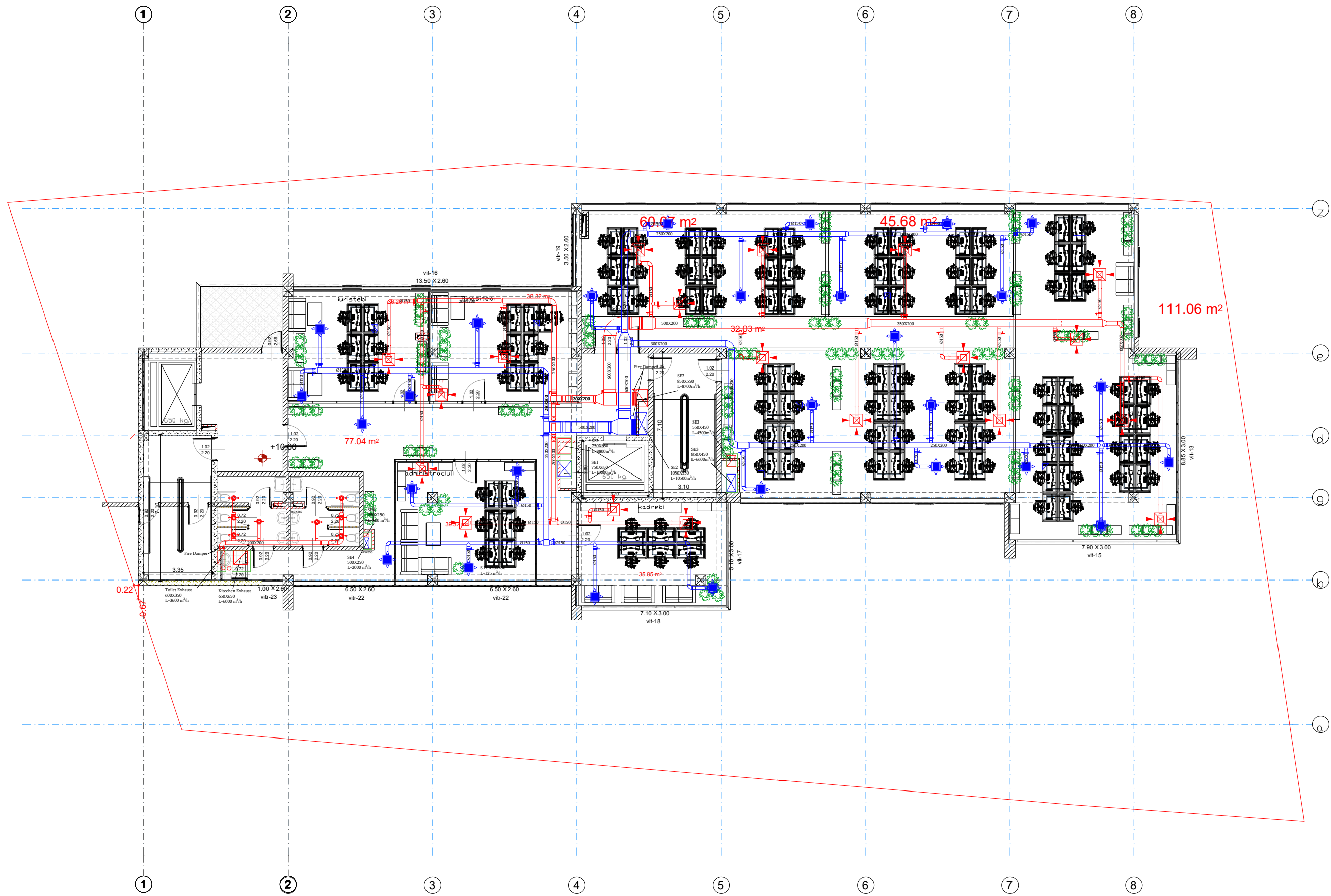

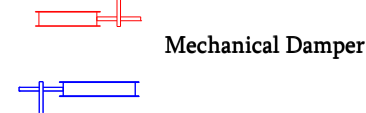
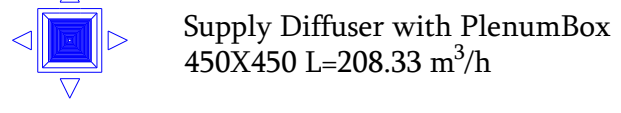
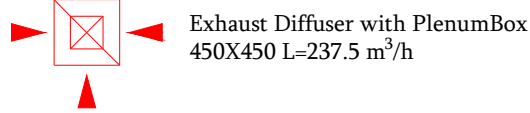
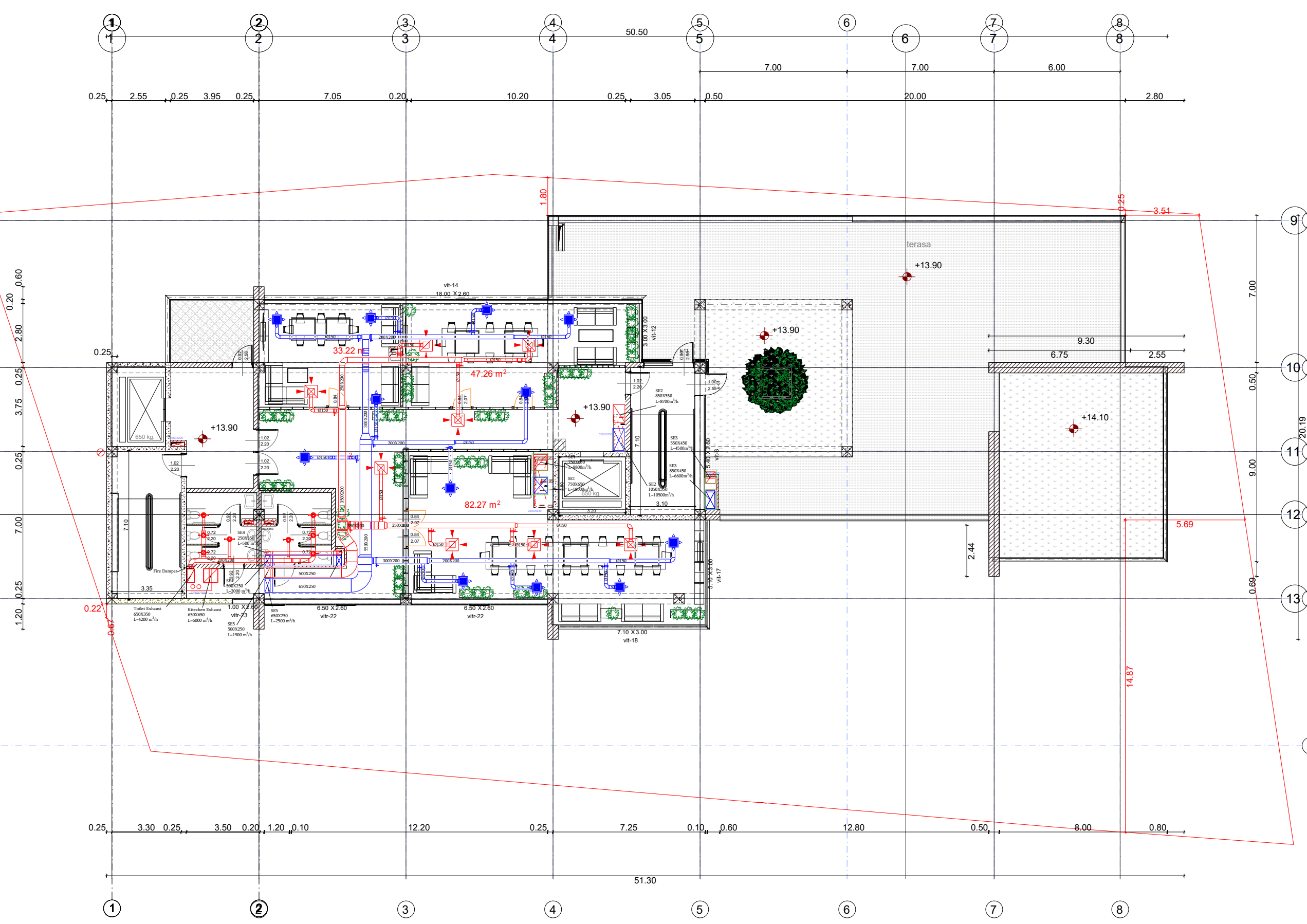

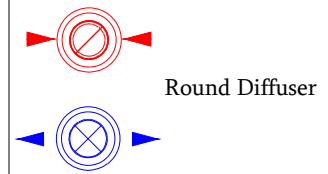
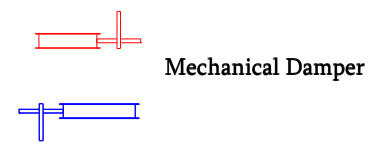
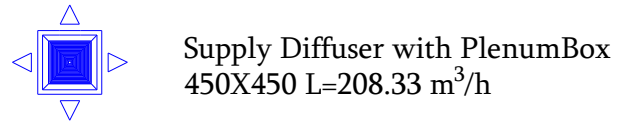
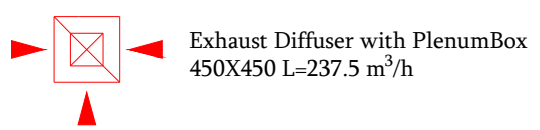
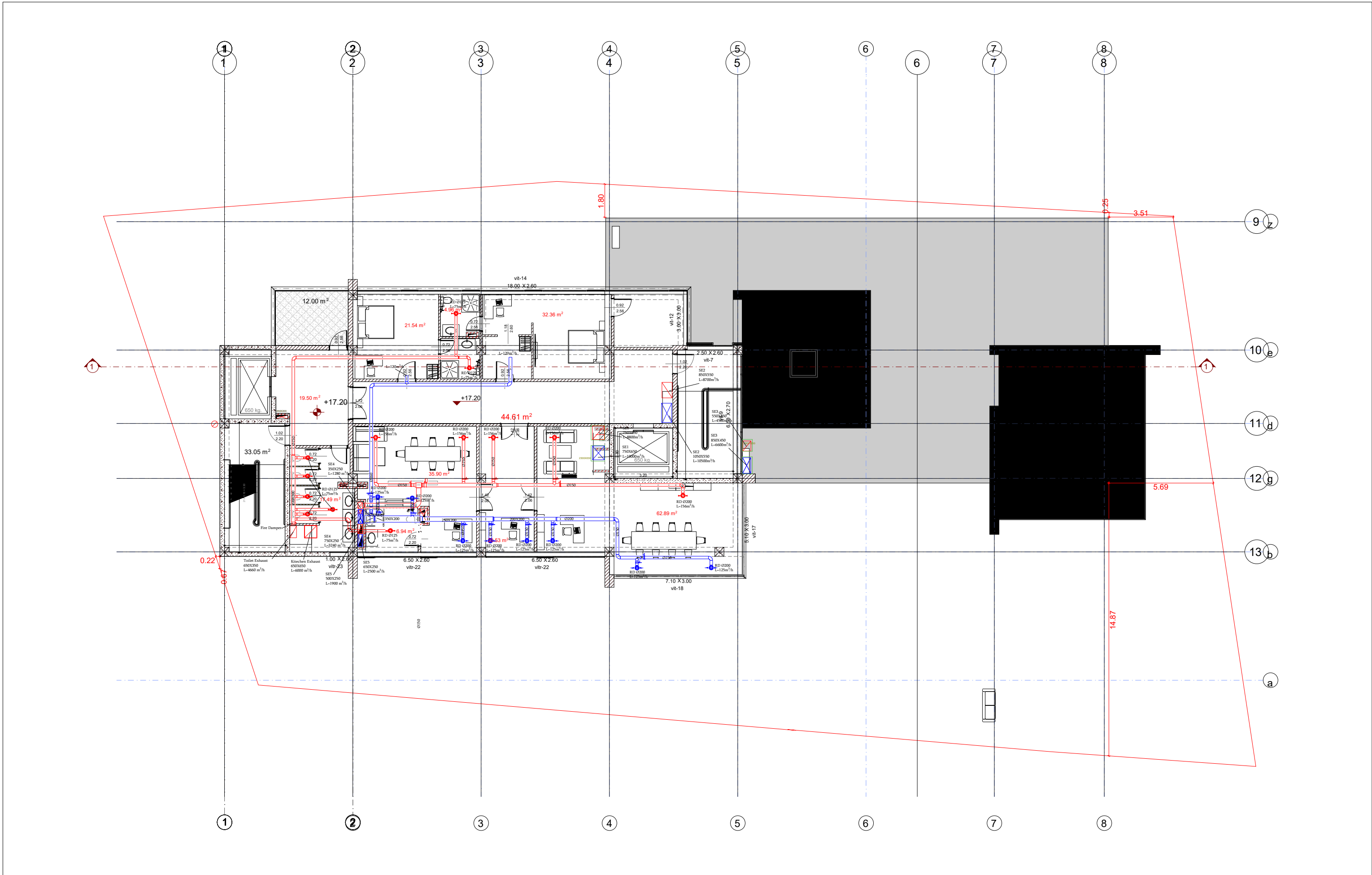

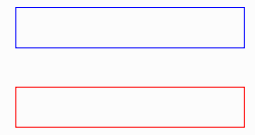
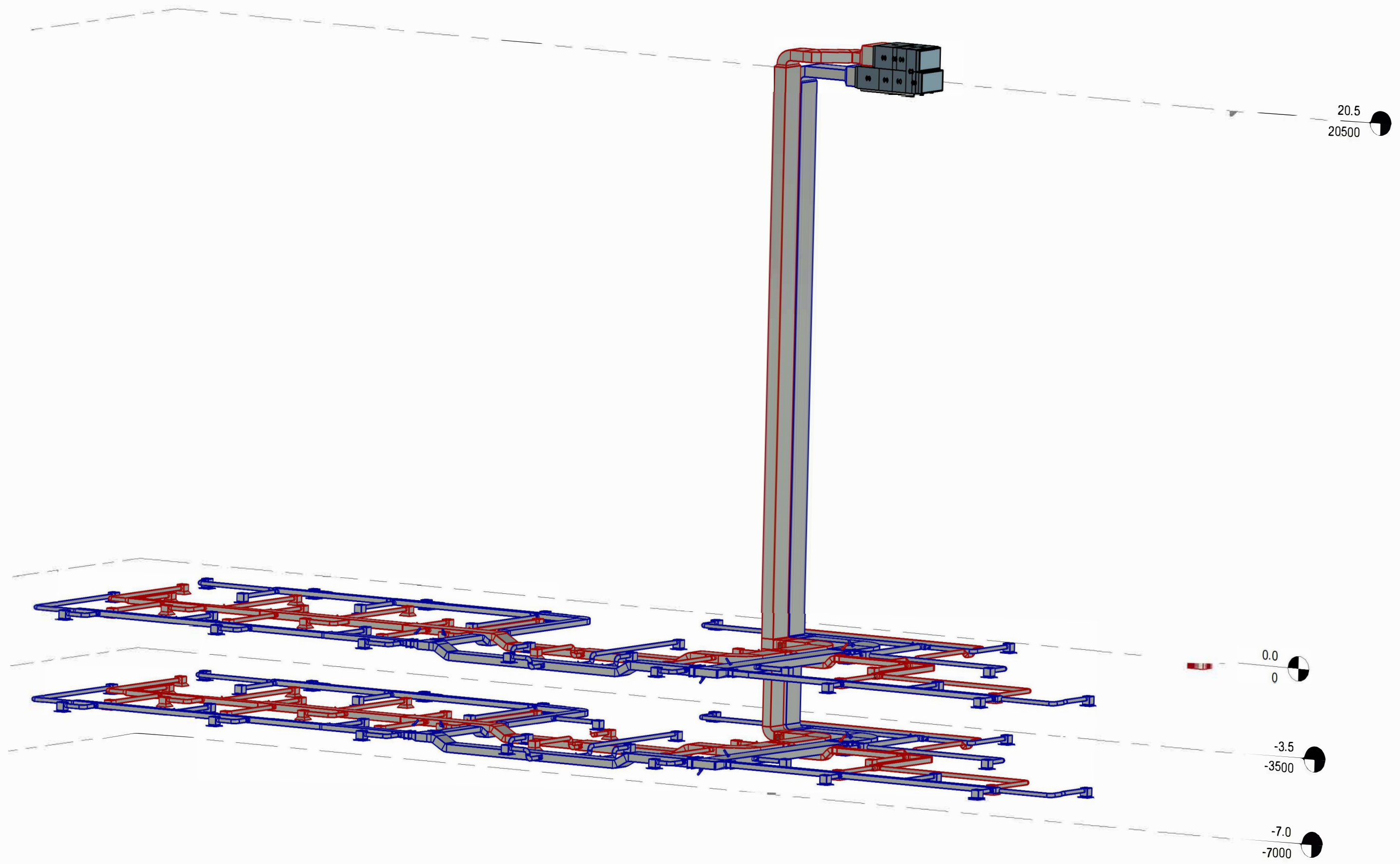

Supply

Exhaust

				Lisi Infiniti	
				Ventilation project	
	Name	Signature	Date	Page	Format
				26	A3

